KAIROS PLUS



KAIROS PLUS 29"



USER MANUAL

INDEX

1. FOREWARD	4
1.1 Generalities	4
1.2 Assistance	4
1.3 Graphic form of safety warnings	4
2. WARNINGS FROM SECURITY	5
2.1 Liability	5
2.2 Warnings for the users	6
2.3 Warnings for there maintenance	6
2.4 Other provisions	7
2.5 Unpacking and seting up	7
2.5.1 Saddle adjustment	7
2.5.2 Pedals assembly	8
3. DESCRIPTION OF THE BICYCLE	9
3.1 General description	9
3.2 Technical form	10
3.3 Levers of the brakes	11
3.4 Speed change	11
3.5 Management system Of assistance	12
3.5.1 Management assistance command	12
3.5.2 Power on/off of the system	12
3.5.3 Assistance activation	13
3.5.4 Levels of assistance	13
3.6 Graphics interface of displays	14
3.6.1 General description screens	14
3.7 Computer mode	15
3.7.1 Race mode	15
3.7.2 Summary mode	16
3.8 Assisted walk mode	17

3.9 Menù	18
3.9.1 Brightness screen	19
3.9.2 Language change	19
3.9.3 Unit Of measure	19
3.9.4 Weight	20
3.9.5 Gender	20
3.10 Error code	20
3.10.1 Resolution of the problems	22
3.11 Battery	23
3.11.1 State Of charge	23
3.11.2 Installation/removal battery	23
3.11.3 Loading battery	25
3.11.4 Resolution of the problems	25
3.12 Suspension	26
4. CONDITIONS OF USE AND ENVIRONMENT EXPECTED	27
4.1 Expected use	27
4.2 Environment of use	28
4.3 Improper use and contraindications	28
5. LIFTING AND TRANSPORT	29
5.1 Lifting	29
5.2 Transportation	29
6. COMMISSIONING	30
6.1 Load of the battery	30
6.2 Checks of foreplay	31
6.2.1 Devices Of command	31
6.2.2 Wheels	31
6.2.3 Braking	31



6.2.4	<i>Position of frame, handlebar and saddle</i>	32
6.2.5	<i>Brakes</i>	33
6.2.6	<i>Suspensions adjustment</i>	33
7.	USE OF THE BICYCLE	34
7.1	Use of the bicycle	35
7.2	Braking	35
7.3	Parking of the bicycle	35
8.	MAINTENANCE	36
8.1	Generalities	36
8.2	Maintenance and daily check	36
8.2.1	<i>Check of tags and pictograms</i>	36
8.2.2	<i>Check of the wheels</i>	36
8.2.3	<i>Check of the brakes</i>	37
8.3	Maintenance and weekly check	37
8.3.1	<i>Washing and cleaning</i>	37
8.3.2	<i>Lubrication and voltage chain check</i>	37
8.3.3	<i>Check of the frame and of the bolts</i>	37
8.4	Maintenance and monthly check	38
8.4.1	<i>Check of the circuits and electrical components</i>	38
8.4.2	<i>Check and regulation of the derailleur</i>	38
9.	TECHNICAL ASSISTANCE AND SPARE PARTS	39
10.	DEPOSIT TO WAREHOUSE	39
11.	DISPOSAL FROM COMPONENTS AND MATERIALS	40
12.	STANDARDS FROM WARRANTY	41
13.	CONFORMITY	42



1. FOREWARD

1.1 Generalities

This manual is an integral and essential part of the pedal assisted bicycle models KAIROS PLUS 29''

Before commissioning, users must read, understand and scrupulously follow the instructions below.

The manufacturer is not liable for damage caused to persons and/or things or to pedal assisted bicycles if they are used incorrectly with respect to the instructions indicated.

With a view to continuous technological development, the manufacturer reserves the right to modify the components, including the frame, without notice and without this manual being automatically updated.

1.2 Assistance

For any inconvenience or request for clarification, contact the authorized dealer, who has competent and specialized personnel, as well as specific equipment and original spare parts.

1.3 Graphical form of security events

To identify the safety messages in this manual, the following graphic signaling symbols will be used. They have the function of attracting the attention of the reader / user for the purposes of correct and safe use of the pedal assisted bicycle.



ATTENTION

It highlights rules of conduct to be followed in order to avoid damage to the pedal assisted bicycle and/or the occurrence of dangerous situations.



DANGER

It highlights the presence of dangers that cause residual risks to which the user must pay attention in order to avoid accidents or damage to property.

2. SECURITY WARNINGS



ATTENTION

USE OF THE PEDAL ASSISTED BICYCLE

Each user must first read the instruction manual, especially the chapter on safety instructions.



ATTENTION

POSSIBLY RISKS

- Despite the application of the safety devices, for safe use of the pedal assisted bicycle you must take note of all the prescriptions relating to the prevention of accidents contained in this manual.
- Always stay focused while riding and **DO NOT** underestimate the residual risks connected with the use of the pedal assisted bicycle

Even if you are already familiar with the use of pedal assisted bicycles, it is necessary to follow the instructions given here, in addition to the general precautions to observe when driving a motorized vehicle. In particular:

- Acquire full knowledge of the pedal assisted bicycle;
- Read the manual carefully to learn about the operation, the safety devices and all the precautions necessary for the safe use of the vehicle. All this to allow safe use;
- Carefully maintain the pedal assisted bicycle in perfect working order.

For any inconvenience or request for clarification, do not hesitate to contact the authorized dealer, who has competent and specialized personnel, specific equipment and original spare parts.

2.1 Liability

Failure to comply with the operating instructions and safety prescriptions contained in this manual exempts the manufacturer from any liability.

If the maintenance of the pedal assisted bicycle is carried out in a way that does not comply with the instructions provided, with non-original spare parts or in any case in such a way as to jeopardize its integrity or modify its characteristics, the manufacturer will consider itself relieved of any responsibility relating to the safety of people and malfunctioning of the pedal assisted bicycle.



**ATTENTION****NOT AUTHORIZED MODIFICATIONS**

If you hear unusual noises, or feel something strange, stop the pedal assisted bicycle immediately. Then carry out a check and, if necessary, contact your authorized dealer.

For any data that is not understood or cannot be deduced from this manual, it is recommended to consult the authorized dealer directly.

2.2 Warnings for the users

1. It is forbidden to carry a passenger.
2. Only to be used by experienced adults and children.
3. Do not take alcohol or drugs before riding the pedal assisted bicycle.
4. These pedal assisted bicycle models are designed and built to be used outdoors, on roads and in private and public environments.
5. Do not ask the pedal assisted bicycle to perform in excess of what it was designed for.
6. Never ride the pedal assisted bicycle with parts removed.
7. Ride with both hands on the handlebars.
8. Replace worn and/or damaged parts and check that the guards work properly before use.

2.3 Warnings for the maintenance

1. All maintenance operations must be carried out with the battery disconnected.
2. During each maintenance phase, the operators must be equipped with the necessary accident prevention equipment.
3. The tools used for maintenance must be suitable and of good quality.
4. Do not use gasoline or flammable solvents as cleaners, always use non-flammable and non-toxic solvents.
5. Limit the use of compressed air for cleaning as much as possible (max 2 bar) and protect yourself with goggles with side guards.
6. Never resort to the use of open flames as a means of lighting when carrying out checks or maintenance operations.
7. After each maintenance or adjustment operation, make sure that no tools or foreign bodies remain between the moving parts of the pedal assisted bicycle.

**ATTENTION****ORIGINAL REPLACEMENT**

Only use original spare parts supplied by M.B.M. S.r.l. Single-member.
The Manufacturer is excluded from any liability for damage or loss of functionality caused by the use of non-original accessories and parts.



2.4 Other provisions

The first thing to do when starting use is to check the presence and integrity of the protections and the functioning of the safety devices. If you find any defects, do not use the pedal assisted bicycle!



DANGER

SHELTERS

It is therefore strictly forbidden to modify or remove the guards, controls, labels and indication plates.

2.5 Unpacking and setting up

The pedal assisted bicycle is delivered fully assembled and functional.

2.5.1 Saddle adjustement

Adjusting the height of the saddle is an essential prerogative for the correct use of the pedal assisted bicycle. Incorrect adjustment can generate structural breaks in the frame.

Adjust the height of the saddle using the screw located in the collar (Ref. A - Figure 1).

Verify that the mechanism is tightened before testing the seat and using the vehicle. Do not tighten the collar screw (Ref. A - Figure 1) beyond the maximum value of 8 Nm. Do not lift the saddle beyond the limit switch located in the tube (Ref. B - Figure 1).

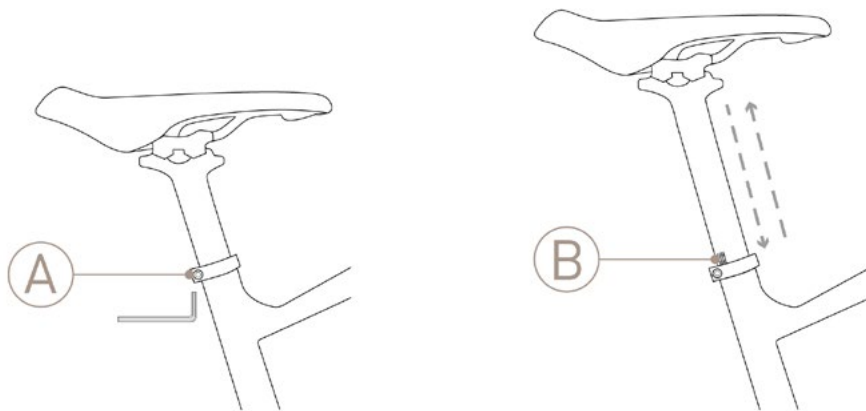

FIG. 1



DANGER

IMPORTANT:

For your safety, the seat post reference mark (B) should never be outside the tube into which the seat post is inserted.



ATTENTION

PACKING

In the event that you do not have the appropriate instrumentation for adjustment or you do not have the skills, contact your authorized dealer.



2.5.2 Pedals assembly

Right Pedal: identified by the letter R marked on its pin. To assemble the pedal, screw it in by turning the pin clockwise. (Figure 2)

Left Pedal: identified by the letter L marked on its pin. To assemble the pedal, screw it in by turning the pin counterclockwise. (Figure 2)



ATTENTION

PACKING

If you do not have the appropriate instruments for adjustment or do not have the skills, contact your authorized dealer.

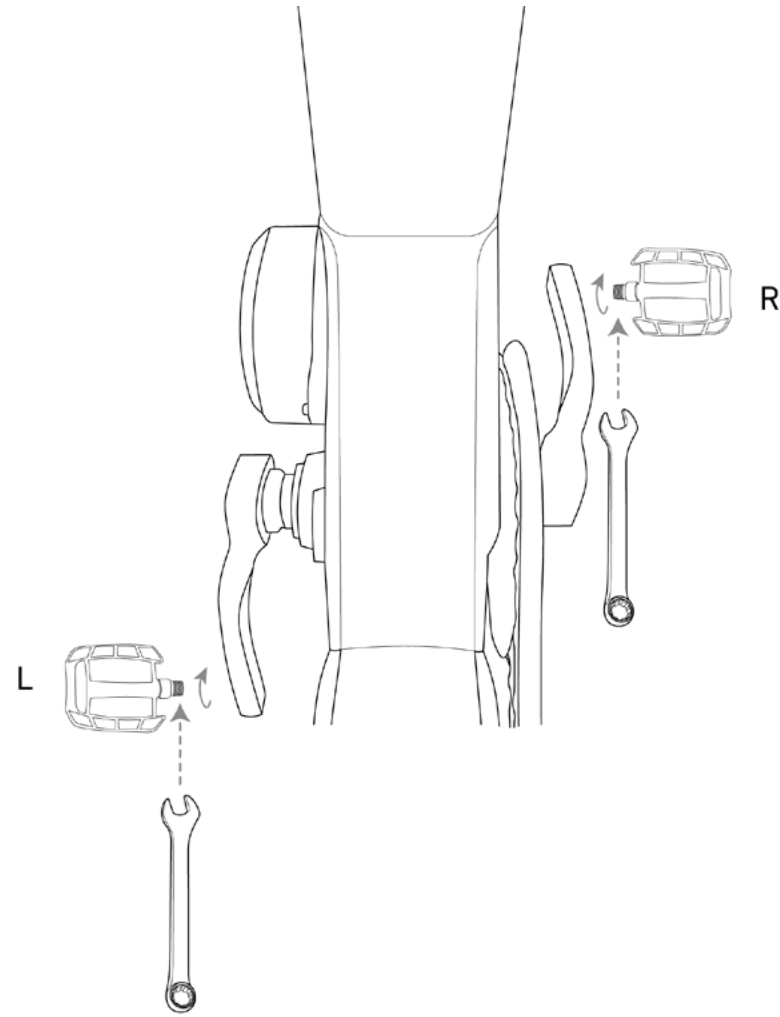

FIG. 2



3. DESCRIPTION OF THE BICYCLE

3.1 General description

The pedal assisted bicycle is designed and built to be used outdoors, on roads and in private or public environments. In particular, the components and the type of pedal assisted bicycle allow you to tackle routes with asphalted surfaces and dirt roads without particular roughness.



INCORRECT AND UNINTENDED USE

The bicycle was designed and built for the specified use; a different use and failure to comply with the technical parameters set by the Manufacturer can constitute a dangerous condition for the users.

The pedal assisted bicycle is equipped with a rechargeable battery and an electric motor, whose intervention takes place only in conjunction with pedaling and progressively stops as the speed of the vehicle approaches 25 km/h, to then stop completely at this speed.

For the management of the assistance system there is a special control located next to the left grip on the handlebar.

On the right side of the handlebar there is a control system for selecting gears.



3.2 Data sheet

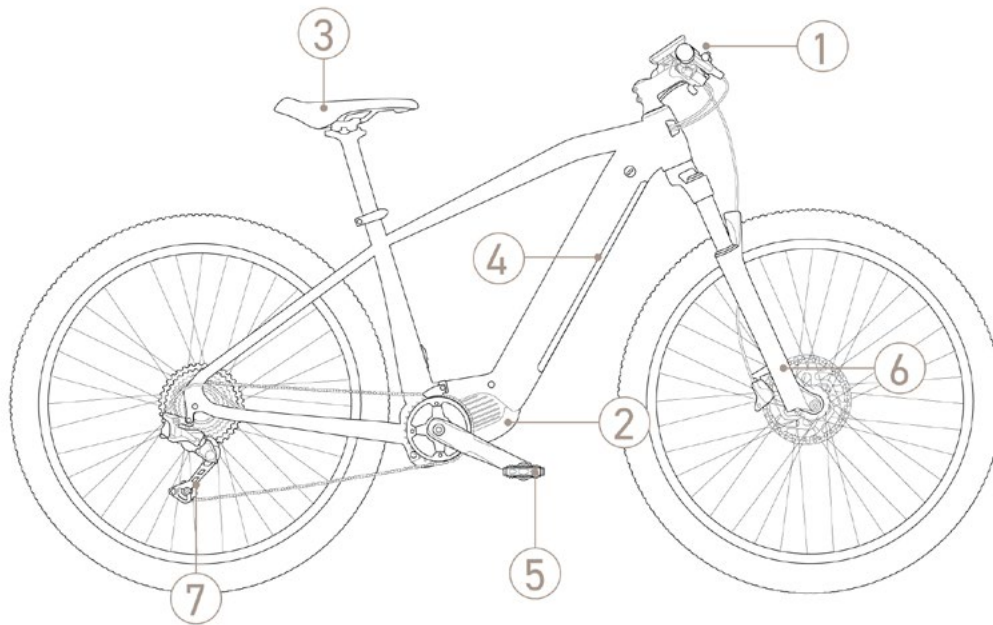

1. HANDLEBAR AND COMMAND
2. MOTOR
3. SADDLE
4. BATTERY
5. PEDALS
6. FORK
7. SHIFTER

CODE	E1329PL
FRAME	HYDROFORMED ALUMINUM
FORK	CUSHIONED WITH ADJUSTMENT
CRANKSET	34 DENTI
SHIFTER	DEORE
SHIFTER COMMAND	11 SPEEDS
BRAKES	SHIMANO MT200 HYDRAULIC
DISKS	SHIMANO RT10 CENTER LOCK 180 F/180 R
TYRES	29*2.60
SADDLE	S SAN MARCO SHORTFIT
PEDALS	RIGHT AND LEFT IN STEEL POLYMER MATERIAL
MOTOR	OLI SPORT PLUS 85 NM
BATTERY	PHYLION INTEGRATED BN-21L, 36V, 14,5 AH, 522 WH
MAX. SPEED ASSISTED	25 KM/H
DISPLAY	LCD
LEVEL OF POWER	5
WEIGHT	25 KG



3.3 Levers of brakes

The brake levers (Ref. C - Figure 3) are located on the handlebar of the pedal assisted bicycle, near the grips (Ref. D - Figure 3). These systems make it possible to control the brake disc calipers, located near the wheel hubs. The right lever controls the rear brake, the left one the front brake; the braking action is proportional to the force applied to the lever.

3.4 Speed changes

The pedal assisted bicycle has an 11-speed shifter with the sprockets positioned on the rear wheel hub and selectable using the opposing levers located at the base of the right knob. The indicator (Ref. E - Figure 3) present in the upper part of the handlebar, it allows you to view the selected ratio.

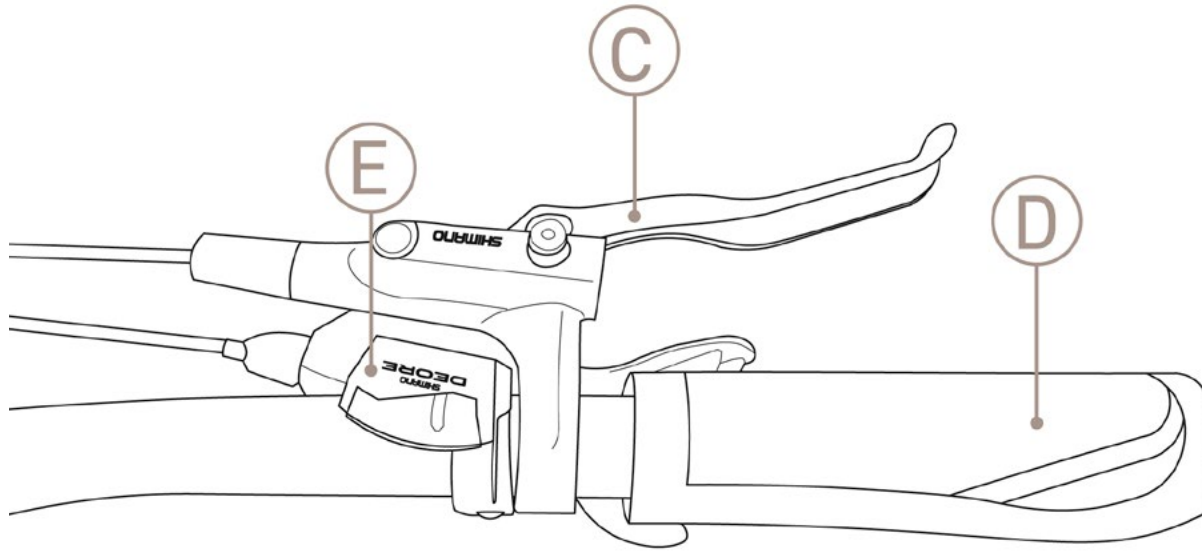

FIG. 3

3.5 Management system of assistance

3.5.1 Management assistance command

The pedal assisted bicycle has, in the center of the handlebar, a display which allows you to manage the operation of the electric motor, as well as other basic functions illustrated below. (Figure 4)

Near the left handlebar grip there are 3 buttons, which can be used with a short or long pressure, thanks to which it is possible to control the functions of the display. (Figure 5)



FIG. 4

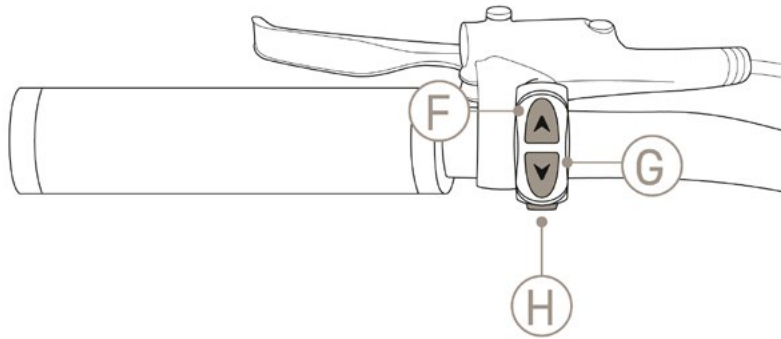

FIG. 5

button	short pressure/ <1 second	long pressure / > 2 seconds
(H) POWER	Allows you to: scroll in the Home from one main screen to another; scroll between the Home and the Menu; confirm the action while editing	Allows you to: turn on and off the display; from the Menu and Advanced section, return to the last screen Home displayed.
(F) UP	It allows scrolling through the menu items, going upwards. It allows increasing the level of assistance.	from any main screen, it allows you to change the operating mode of the lights
(G) down	allows you to scroll down through the menu items. allows you to reduce the level of assistance.	from any main screen, it allows you to activate Walk mode
(F + G) DOWN + UP	-	from the main screens, pressing the two keys at the same time allows access to the menù

3.5.2 Power on/off of the system

To activate the system, press the "POWER" key (Ref.H - Figure 5) until the start-up diagram is displayed or press the "ON" button on the battery. To turn off the display, press and hold the "POWER" key until the shutdown screen appears, or, press the "OFF" button on the battery. If the E-Bike is not used for a variable amount of time, depending on the battery, the system will switch off automatically.



3.5.3. Assistance activation

The thruster activates and deactivates immediately if pedaling stops. The engine power depends on the force exerted on the pedals, according to a multiplier factor depending on the level of assistance selected.

3.5.4 Levels of assistance

The assistance level can be changed from any screen in the Home section by pressing the "UP" key (Ref. F - Figure 5) to increase it and the "DOWN" key (Ref. G - Figure 5) to decrease it.

Multiplication factor for each level of assistance:

LEVEL 0 - NO ASSISTANCE

LEVEL 1 - ASSISTANCE 12,5%

Recommended route: flat - long distances

LEVEL 2 - ASSISTANCE 25%

Recommended route: flat/hilly - medium-long distances

LEVEL 3 - ASSISTANCE 50%

Recommended route: hilly/medium climb - medium mileage

LEVEL 4 - ASSISTANCE 75%

Recommended route: uphill - medium-short distances

LEVEL 5 - ASSISTANCE 100%

Recommended route: demanding climb - short route

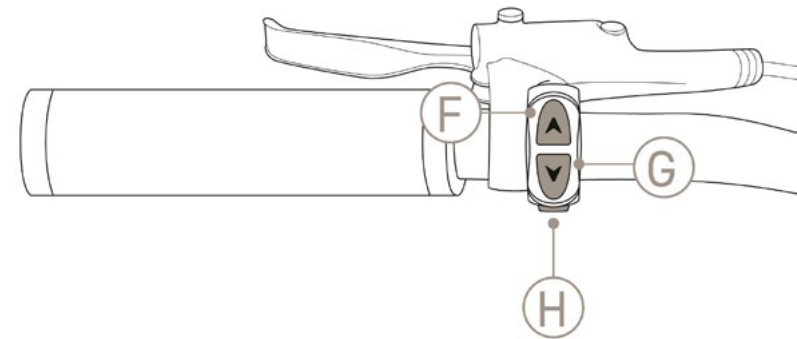

FIG. 5



ATTENTION

ATTENTION:

The system has 5 levels of assistance which increase the power supplied by the motor. If level 0 is set, assistance is deactivated



3.6 Graphic interface of display

After switching on, the first Distance screen of the Home section is displayed. The Home section consists of 6 screens. To scroll through the screens it is necessary to press the "POWER" key.

- From any screen in the Home section, you can:
- > adjust the assistance level by pressing the "UP" and "DOWN" buttons;
 - > enter Walk mode by holding down the "DOWN" key;
 - > enter the Menu section by holding down the "UP"+"DOWN" keys simultaneously for 2".

3.6.1. General composition screens

The Home section screens differ from each other in the type of information that is displayed. (Figure 4.1)

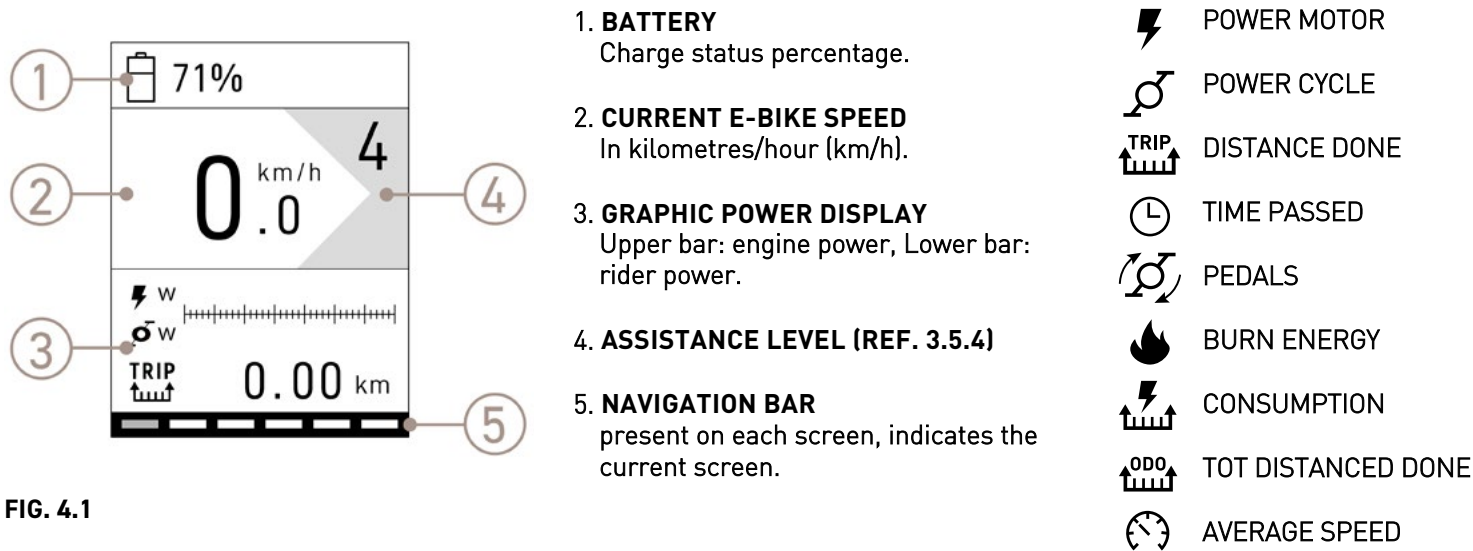

FIG. 4.1



3.7 Computer mode

H\Y'cb!VcUfX'Wca di hYf'jg'UV'Y'hc'UXUdh'hc'j Uf]ci gi' gU[Y'g'W'WbUf]cgZ'Z'ca 'Wca a i h]b['hc'gdcfhg'i gY"
Hc'a cj Y'VY'fk YYb'h\Y'Uj U]UV'Y'X]gd'Uma cXYgZ'Vf]YZ'ndfYgg'h\Y'~DCK 9F "'_Ymif'YZ'<! :] [i fY') Է'

3.7.1. "RACE" A cXY

h]g'h\Y'Z'h'g'W'YYb'cZ'h\Y'<ca Y'g'Y'W]cb"

h' h]g'g'W'YYb'h\Y'j U'i Yg'j]b'k Uhtg'fk Է'cZ'h\Y'Yb[]bY'dck Yf'UbX'W'W]ghdck Yf'UFY'YI dfYggYX'j]b'Z' ~"'f]] [i fY' ("&Է'
H\jg'a cXY'cZi gY'jg'Uja YX'UhYI dYfhi gYfg'UbX'Zc'f'gdcfhg'i gY'cZ'h\Y'YI V]_Y"'f]] [i fY' ("&Է'

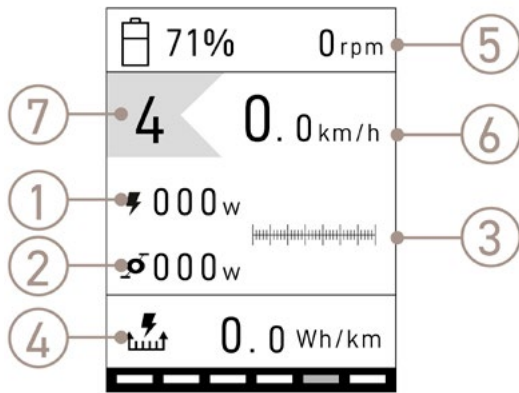

FIG. 4.2

⚡ % POWER
 h'g'Uht'h\Y'j]bghUbtUbyci g'dck Yf'XY'j] YfYX'Vm
 h\Y'a chcf'j]b'k Uhtg'fk Է'

♂ "&" POWER CYCLIST
 hX]W]hg'h\Y'j]bghUbtUbyci g'dck Yf'YI dfYggYX'Vmt'h\Y'W'W]gh]b'k Uhtg'fk Է'

||||| " POWER VISUALISATION
 ; fUd\jWX]gd'UmcZdck Yf'i ddYf'VUf. Yb[]bY'dck Yf'ck Yf'VUf. W'W]gh
 dck Yf"

⚡ (" ENERGETIC CONSUMPTION
 hX]W]hg'h\Y'Uj YfU[Y'Ybyf[m'W'cbgi a dh]cb'j]b'k Uht \ci fg'dYf'_]ca YHf'
 fk \#_a Է'~'W'W'UH'X'g]b'W'h\Y'~UghfYgYH'h\jg'XUH'a U_Yg'j]hdccg]V'Y'hc
 UX'gh'h\Y'Y'Y'UbX'h\YfYzcfY'h\Y'W'cbgi a dh]cb'cZ'h\Y'Y6_Y'U'W'W'fX]b['hc
 bYYX'6m'W'W'UH]b['h\Y'fU]c'VY'fk YYb'h\jg'Z[i fY'UbX'h\Y'VUhtYfm
 W]dU'V]mz'nci [Yh'h\Y'YI U'W'Ua ci bhicZ]ghUbtW' dccg]V'Y'Zc'f'YU'W' W'Uf[Y"

)" RHYTHM

*" CURRENT SPEED

+ " LEVEL OF ASSISTANCE

65HH9FM- 7CBGI DHCB'1 ?a 'dfU'W'W'Y



3.7.2. Resume mode

It is the sixth screen of the Home section.

This screen summarizes the variable parameters from the previous screens. (Figure 4.3)

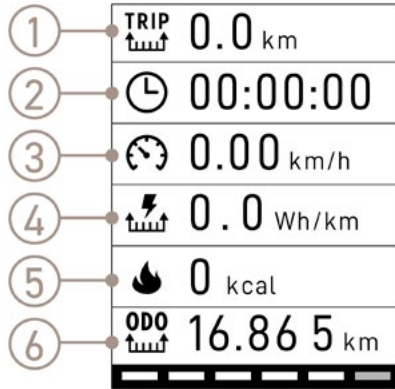

FIG. 4.3

1. Indicates the distance traveled in kilometers (km) since the last reset.
2. Indicates the elapsed time in motion since the last reset. The value is expressed in hours:minutes:seconds.
3. Indicates the average speed in kilometers per hour (km/h) recorded since the last reset.
4. Indicates the average energy consumption in watt-hours per kilometer (Wh/km), calculated since the last reset.
5. Indicates the energy consumed by the cyclist in kilocalories (kcal) since the last reset.
6. Indicates the total distance traveled by the eBike in kilometers (km). Non-resettable value.



3.8 Walk assistance mode

The system is equipped with a walking assistance function that allows you to activate the motor up to a maximum speed of 6 km/h, to make it easier to tackle short stretches by pushing the e-bike.

To activate the walk assistance function, hold down the "DOWN" key (ref. G in Figure 5). The engine will start and the appropriate warning will appear on the display. The engine will deactivate in the following cases:

- Release of the "DOWN" button (Ref. G in Figure 5);
- Speed higher than 6km/h;
- Locking of the e-bike wheel.

NOTE: By selecting the assistance level "0" the motor is completely disabled and it is not possible to use the walking assistance mode.



ATTENTION

Before activating the walking assistance mode, hold the handlebar firmly to avoid injury.

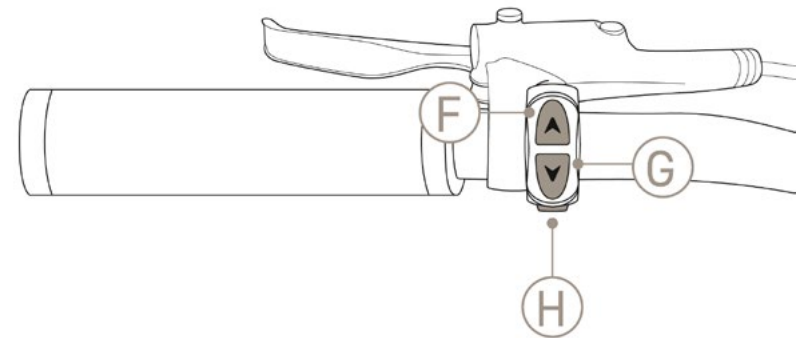

FIG. 5



3.9 Menù

By pressing the "UP"+"DOWN" buttons (Ref. F - G - Figure 5) simultaneously for two seconds, it is possible to open the menu screen. From any screen, by holding down the "POWER" key for 2 seconds, you can return to the last Home screen displayed. Once entered, it is possible to move in the menu with the "UP" and "DOWN" buttons and press "POWER" to enter.



ATTENTION

Before pressing the F and G keys at the same time (Figure 5), position yourself firmly on the bike and apply the brake, so as not to accidentally activate the start-from-standby mode.

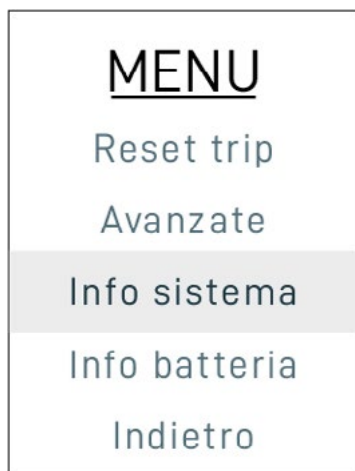

FIG. 4.4

TRIP RESET

The Reset trip item allows you to reset all recorded lap data by resetting the counters to zero (0).

ADVANCE

By selecting this function, you enter the advanced settings menu.

SYSTEM INFO

In this screen it is possible to view the versions of the firmware, of the installed graphical user interface and of the associated motor.

BATTERY INFO

By selecting this function, you can view the battery information.

BACKWARDS

By selecting this function, you return to the initial screen.

By selecting the ADVANCED setting, you enter the advanced settings menu, in which it is possible to modify or check the essential parameters of the display. Specifically, you can change the brightness, language, unit, weight, gender and night mode. (Figure 4.5)

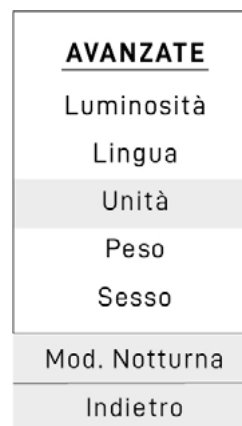

FIG. 4.5



3.9.1. Brightness screen

From this screen you can adjust the brightness of the screen. Use the "UP" and "DOWN" keys to scroll through the values from 1 to 10. The selected value is highlighted in the middle of the white line. (Figure 4.6)

<u>LUMINOSITA'</u>
4
5
6
7
8

FIG. 4.6

3.9.2. Language change

From this screen you can choose the language of the unit texts. Use the "UP" and "DOWN" keys to scroll through the available items. The selected value is highlighted in the middle of the white line. (Figure 4.7)

<u>LINGUA</u>
Italiano
English
Français
Deutsch
Español

FIG. 4.7

3.9.3 Unit of measure

From this screen it is possible to select the unit of measure with which they are calculated:

- > instantaneous speed;
- > average speed;
- > average consumption;
- > lap distance;
- > total distance.

Use the "UP" and "DOWN" keys to scroll through the available items. The selected value is highlighted in the middle of the white line. (Figure 4.8)

<u>UNITA'</u>
Km
Miglia
Indietro

FIG. 4.8



3.9.4 Weight

From this screen you can set your body weight by choosing a value between 50 and 150 kg. The setting of this datum is not necessary for the correct functioning of the eBike. The value has the sole purpose of making the calculation of calories consumed reliable. Use the up and down keys to scroll through the available items. The selected value is highlighted in the middle of the white line. (Figure 4.9)

<u>PESO</u>
68
69
70
71
72

FIG. 4.9

3.9.5 Gender

From this screen you can set your gender. The setting of this datum is not necessary for the correct functioning of the eBike. The value has the sole purpose of making the calculation of calories consumed reliable. Use the up and down keys to scroll through the available items. The selected value is highlighted in the middle of the white line. (Figure 4.10)

<u>SESSO</u>
Femmina
Maschio
Indietro

FIG. 4.10

3.10 Error code

In the event of an anomaly, the system notifies the user of the problem by displaying a danger icon combined with a 4-character code which allows the type of error to be traced.

Depending on the type of fault, the system could prevent the engine from starting or make it run at reduced power. Where "request assistance" is indicated, the intervention of a specialized OLI eBike Systems technician is required.



ATTENTION

Depending on the type of fault, the system could prevent the engine from starting or running at maximum power.



ERROR CODE	DESCRIPTION
0001	BATTERY COMMUNICATION PROBLEM. BATTERY STATUS DATA MAY BE DISPLAYED INCORRECTLY CHECK THAT THE WIRING AND BATTERY CONTACTS ARE CONNECTED CORRECTLY AND INTACT.
0101	COMMUNICATION PROBLEM BETWEEN DRIVE AND HMI. CHECK THAT THE CABLES ARE CONNECTED CORRECTLY AND INTACT.
0104	SPEED SENSOR NOT DETECTED. CHECK THAT THE ALIGNMENT BETWEEN THE MAGNET AND THE SPEED SENSOR IS CORRECT CHECK THAT THE SPEED SENSOR IS INSTALLED AND CONNECTED CORRECTLY.
0105	TORQUEMETER SIGNAL NOT COMPLIANT. THE TORQUE TRANSDUCER SIGNAL HAS AN ANOMALY. OPERATION AT REDUCED POWER.
0106	NON-COMPLIANT TORQUE TRANSDUCER OFFSET. THE TORQUE TRANSDUCER SIGNAL HAS AN ANOMALY.
0801	FAULT IN THE ENGINE ROTATION SENSORS.
0802	FAULT IN THE PEDAL ROTATION SENSORS.
0804	EXCESSIVE DRIVE TEMPERATURE. THE TEMPERATURE SENSOR HAS DETECTED A TEMPERATURE ABOVE THE DANGER THRESHOLD.
0805	EXCESSIVE ENGINE TEMPERATURE. THE ENGINE HAS REACHED A TEMPERATURE ABOVE THE DANGER THRESHOLD.
0806	PERIPHERAL BUS VOLTAGE NOT COMPLIANT.
808	ROTOR BLOCKED. THE ENGINE FAILED TO START DUE TO A MECHANICAL BLOCK OR A PROBLEM WITH THE INTERNAL WIRING OF THE DRIVE UNIT.
0809	THE BATTERY VOLTAGE IS HIGHER THAN THE MAXIMUM ALLOWED.
0810	CURRENT SENSOR SIGNAL NOT COMPLIANT.
0811	THE DRIVE HAS DETECTED AN OVERCURRENT.
1101	COMMUNICATION PROBLEM BETWEEN HMI AND DRIVE. CHECK THAT THE CABLES ARE CONNECTED CORRECTLY AND INTACT.
1102	A BUTTON ON THE HANDSET IS LOCKED IN THE PRESSED POSITION.



3.10.1 Resolution of the problems

PROBLEM	CAUSA/SOLUZIONE
The system does not turn on	Check that the battery is inserted correctly in place, and that it is charged.
The assistance does not activate	Check that the selected assistance level is greater than 0, and that the battery charge level is sufficient.
The display shows an error message.	The system has detected an anomaly. Depending on the type of anomaly, the engine could be deactivated or run at reduced power.
The display glass is foggy.	In response to sudden changes in environmental conditions, condensation may form inside the glass. The condensation will disappear once the temperature stabilizes.



ATTENTION

If after these operations the problem persists, request support from a service centre.



3.11 Battery

The bicycle provides pedaling assistance through an electric motor powered by the battery located in the down tube of the frame structure (Figure 6)

3.11.1 State of battery charge

The battery charge status can be viewed directly on the assistance system management display.

3.11.2 Installation/ removal of the battery

To remove the battery, make sure the assistance system is off and proceed as follows:

1. Insert the battery lock/unlock key in the appropriate lock in the upper left part of the frame, near the handlebar, and turn the key counterclockwise. (Ref. K - Figure 7);
2. Keeping the key turned and release the battery (Ref.2 - Figure 7);
3. Pull the battery out all the way being careful not to hit the frame.

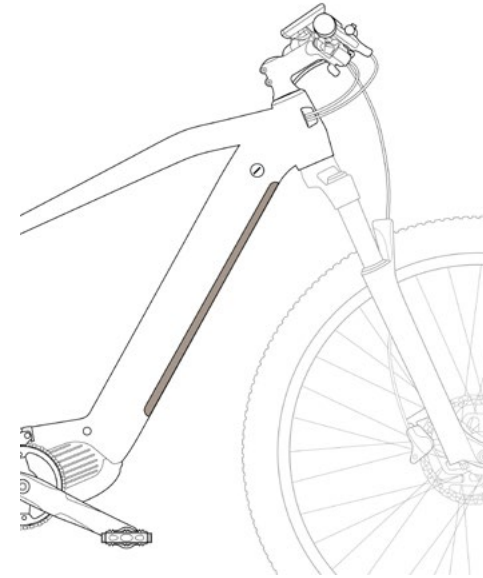

FIG. 6

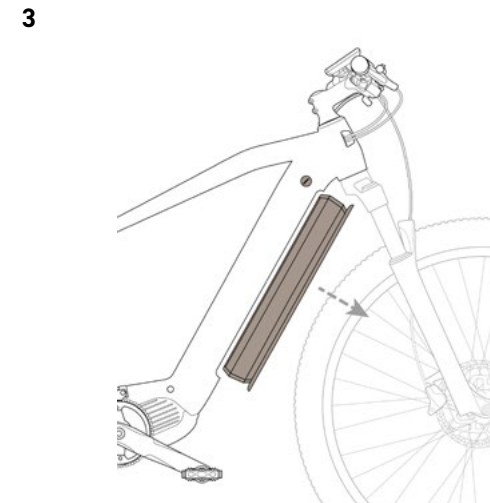
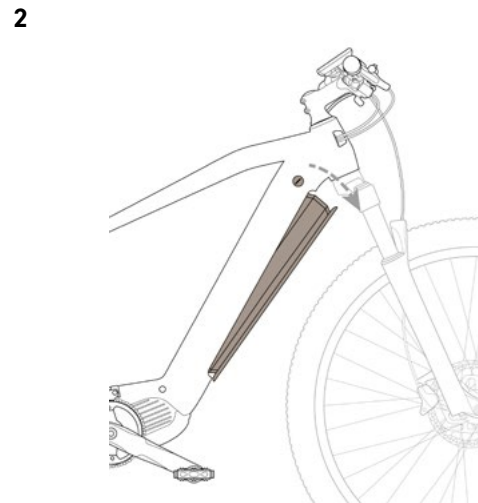

FIG. 7

To install the battery, proceed as follows (this procedure must be performed without the release key, remove it if inserted):

- 1- Align the battery by matching the electrical connector first (Ref. 0 - Figure 8);
- 2- Carefully insert the battery into the frame until you hear the lock click. At this point the battery is already automatically blocked.

1



2

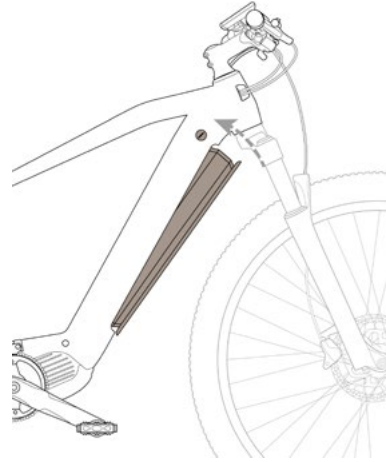

3

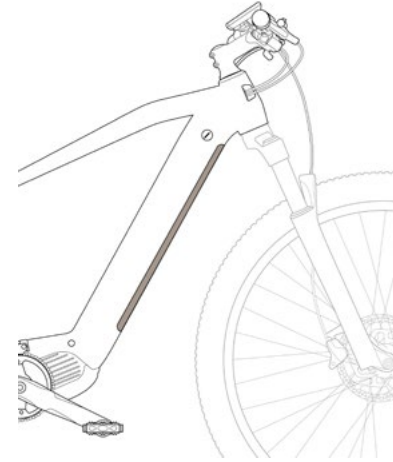
**FIG. 8**

3.11.3 Battery loading

The battery of the pedal assisted bicycle can be recharged in two ways.

- The first by connecting the battery charger directly to the frame via the appropriate socket (Figure 9).
- The second mode involves removing the battery. To charge the battery, proceed as follows:
 1. Turn off the assistance system of the pedal assisted bicycle using the appropriate "MODE" button (Ref. H in Figure 5);
 2. Remove the battery;
 3. Connect the supplied battery charger to the socket with the appropriate plug (Figure 9.1)
 4. Connect the battery charger to a power outlet (230 V / 50 Hz) and charge the battery for the necessary time.

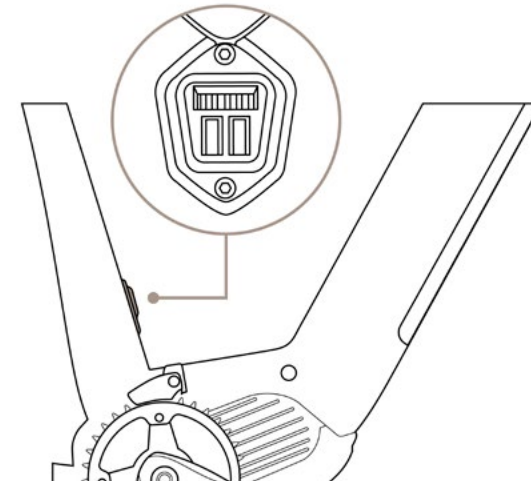

FIG. 9

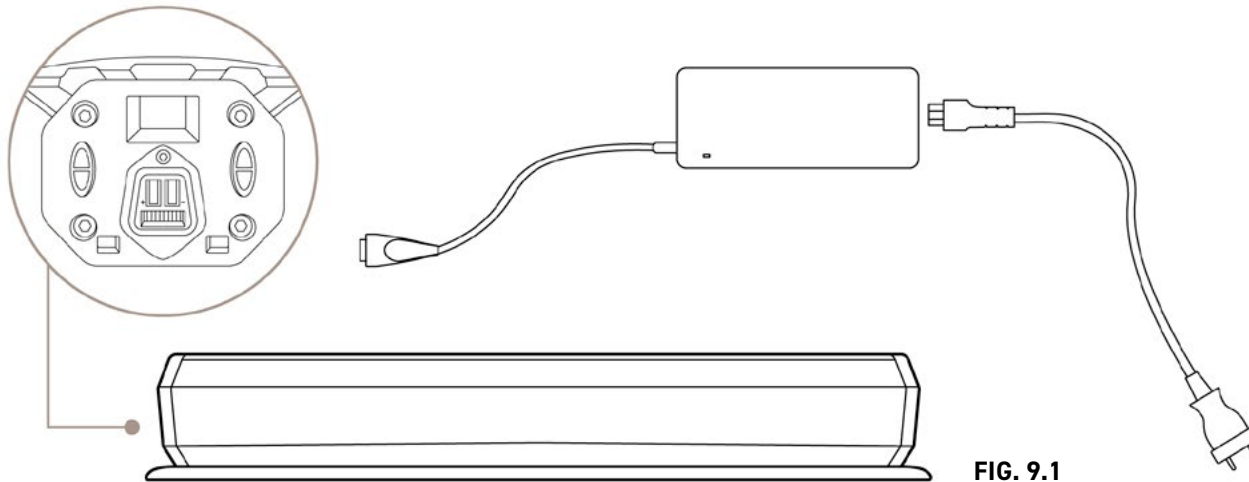

FIG. 9.1



ATTENTION

BATTERY CHARGER

Always connect the plug to the battery first and then the charger to the socket.



3.11.4 Resolution of the problems

PROBLEM	SOLUTION
The system do not turn on	Check the battery
Assistance do not active	Check the level of battery is enough



ATTENTION

RESOLUTION OF THE PROBLEMS

If the assistance system does not activate even if the battery is charged, contact your authorized dealer.

3.12 Suspensions

The pedal assisted bicycle is equipped with a front suspension system which allows to dampen the stresses caused by the roughness of the road. The suspension model turns out to be adjustable by means of special adjustment controls on the upper and lower part of the forks. In particular, it is possible to vary the preload of the forks by turning the lever in the upper left part (Ref. Q - Figure 10.1) according to the characteristics of the user and the terrain. The blue handle positioned at the top right (Ref. P - Figure 10.1) instead, allows you to block the compression, effectively transforming the suspension from cushioned to rigid. Furthermore, it is possible to adjust the return speed of the suspension itself by turning the red knob positioned in the lower right part of the fork (Ref. R - Figure 10.2).

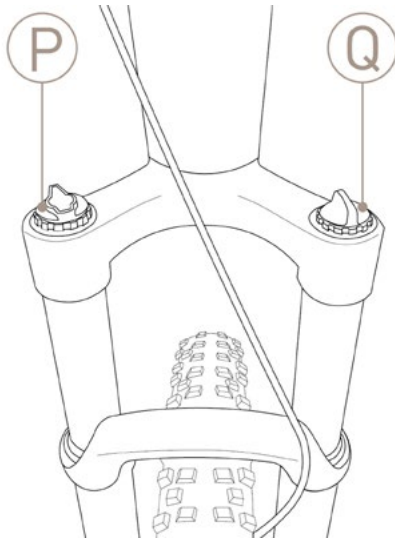

FIG. 10.1

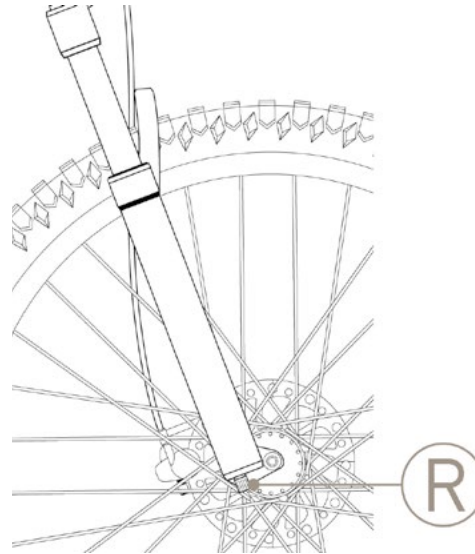

FIG. 10.2



4. CONDITIONS OF USE AND EXPECTED ENVIRONMENTS

4.1 Expected Use

The pedal assisted bicycle is designed and built to be used outdoors, on roads and in private or public environments. In particular, the components and the type of pedal assisted bicycle allow you to tackle routes with asphalted surfaces, or with similar characteristics, without particular roughness.

Any modification to the state of construction can compromise the behaviour, safety and stability of the pedal assisted bicycle and can lead to an accident.

Other types of use, or the extension of use beyond that foreseen, do not correspond to the destination attributed by the manufacturer, and therefore, the same cannot assume any responsibility for any resulting damage.

4.2 Environment of use

The pedal assisted bicycle can be used outdoors, in the absence of adverse weather conditions (heavy rain, hail, snow, strong wind, etc.):

- Maximum permitted temperature: +40 °C;
- Minimum temperature allowed: 0 °C;
- Maximum humidity allowed: 70%;

The environment of use may have an asphalted surface or one with not excessively high roughness. Furthermore, the place of use must be illuminated, by the sun or by artificial lights, in such a way as to guarantee the correct vision of the path and of the controls of the pedal assisted bicycle (recommended from 300 to 500 lux). The pedal assisted bicycle is equipped with a white light front and a red light rear.



ATTENTION

PROHIBITED USE ENVIRONMENTS

The pedal assisted bicycle must not be used:

- In areas subject to risk of fire or explosion;
- In environments with a corrosive and/or chemically active atmosphere;
- In poorly lit environments;
- On excessively inaccessible terrain, given the characteristics of the same (chassis, wheels, etc.);
- In closed spaces, if they do not allow safe use;
- In extremely dark environments.



4.3 Improper use and contraindications

The actions described below, which obviously cannot cover the entire range of potential possibilities of "misuse" of the pedal assisted bicycle, are to be considered absolutely prohibited.



ATTENTION

FORBIDDEN OPERATIONS

- Carrying out prohibited operations invalidates the guarantee;
- The manufacturer declines all responsibility for any damage to people or things deriving from the execution of prohibited operations.



DANGER

ABSOLUTELY FORBIDDEN

- use the pedal assisted bicycle for uses other than those for which it was built, i.e. the pleasure of a passenger;
- Drive the pedal assisted bicycle in areas where there is a danger of explosions;
- Riding the pedal assisted bicycle in adverse weather conditions (heavy rain, hail, snow, strong wind, etc.)
- Driving the pedal assisted bicycle under the influence of alcohol or drugs;
- Ride the pedal-assisted bicycle if your weight is higher than permitted;
- Charge the battery in a too hot or insufficiently ventilated environment;
- Cover the battery while recharging;
- Smoking or using open flames near the recharging area;
- Transit or stop on sloping surfaces (greater than 10%) or excessively bumpy surfaces (with holes, depressions, obstacles, etc.)
- Carry out any maintenance operation with the battery connected;
- Use non-original spare parts;
- Insert your limbs or fingers between the moving parts of the bicycle;
- Use the pedal assisted bicycle on unpaved terrain or with similar characteristics;



5. LIFTING AND TRANSPORTATION

5.1 Lifting

The weight of the KAIROS PLUS model pedal assisted bicycle is such that it can be lifted and carried by a person, also due to the overall dimensions. The optimal solution to carry out the movement is to grasp a handle grip and the rear part of the saddle.



DANGER

CRUSHING AND IMPACT

- **Extreme caution must be exercised during lifting to avoid damage to persons and property.**
- **This operation must be performed by strong people.**

The manufacturer is not liable for breakages due to the lifting and/or transport of the pedal assisted bicycle after delivery.

5.2 Transportation

To ensure safe transport in vans, it is necessary to prevent the pedal assisted bicycle from moving. This is obtained by binding it with anchoring bands or cables in good condition. In this regard, the attachment devices must be installed in such a way as not to damage the frame and other parts of the bicycle.



DANGER

RISK OF INJURY

ALWAYS make sure that the frame and handlebar adjustment bolts are fully tightened before each use of the bicycle. Failure to do so could result in injuries, even serious ones!



6. COMMISSIONING

6.1 Battery loading

Before using the bicycle for the first time, charge the battery for at least 8 hours, using the special battery charger supplied. The pedal assisted bicycle, model HYPERION, is equipped with an electric motor powered by a 36 V lithium-ion battery. The battery pack is housed in the central part of the frame, inside the oblique tube.

The average recharge time varies from 4 to 6 hours.

The recharging operation can be carried out in a well-ventilated box with the battery installed on the bicycle. To charge the battery, proceed as in paragraph 3.11.3.

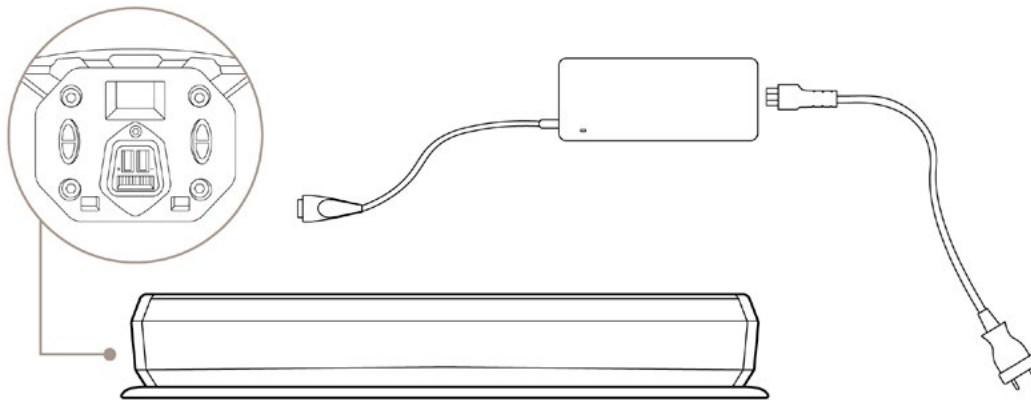

FIG. 9.1



ATTENTION

BATTERY CHARGER

Always connect the plug to the battery first and then the battery charger to the power outlet.



ATTENTION

LOADING OF THE BATTERY

The battery should not be completely discharged to preserve its lifespan and avoid the risk of damaging it. In any case, it must be recharged at least every 3 months, even if the bicycle is not being used.



PERICOLO

PRECAUTIONS DURING CHARGING.

- Always connect the plug to the battery and then the power plug to the mains;
- When recharging is completed, always disconnect the plug from the mains first and then the plug from the battery;
- Always fully recharge the battery;
- Always use the original power supply supplied;
- Do not leave the battery charged for more than 8 hours;
- Always recharge in a ventilated environment;
- Do not recharge the battery in too hot environments;
- Do not recharge the battery near flammable liquids;
- Do not cover the battery in any way during recharging;
- If the battery emits a bad smell, immediately disconnect the plug from the power supply and ventilate the room.



6.2 Functional check foreplay

Before each use, the driver must check the safety status of the pedal assisted bicycle. Therefore, perform the following inspections before riding the pedal assist bicycle.

6.2.1 Command devices

Check the efficiency and state of charge of the battery. Use in very cold environments quickly degrades battery efficiency. Check chain tension and lubrication.

6.2.2 Wheels

Check the tire inflation pressure. Check the state of wear of the tread: there must be no cuts, cracks, foreign bodies, abnormal swellings, visible plies and other damages.



Do not inflate the tires beyond the admissible value indicated by the manufacturer on the side surface of the same.

ATTENTION

6.2.3 Braking system

Visually inspect the braking system, checking that there are no damaged cables or lubricants on the braking surfaces of the brake and rim. Check the operation of the brakes by testing the brakes at low speed in an obstacle-free area, first with the rear brake and then with the front brake. Test the efficiency of the braking system on a flat road and at low speed.



NEGATIVE VERIFICATION

In the event that, during the preliminary checks, defects of any kind are found and even one single check is negative, DO NOT RIDE THE BIKE WITH PEDAL ASSISTANCE. Immediately activate all measures to carry out an appropriate repair and, if necessary, contact your authorized dealer or an authorized workshop.

ATTENTION



6.2.4 Position of the frame and saddle

Check that the frame and saddle are properly secured and positioned in the most comfortable configuration for the rider to have complete control of the bicycle. Otherwise, before setting off, act on the saddle position adjustment systems. For further information on the regulation, refer to paragraph 2.5.

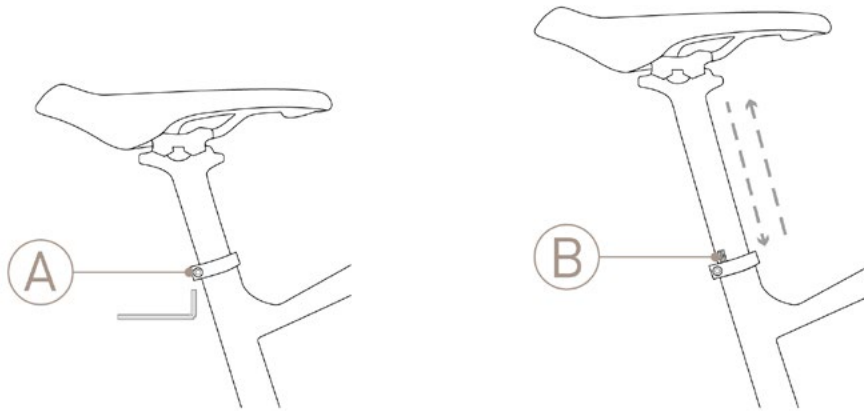

FIG. 1



IMPORTANT NOTICE:
Check that the minimum insertion mark (B) is not visible.

6.2.5 Regulation of brakes

Before using the pedal assisted bicycle, adjust the position of the brake levers on the handlebar to obtain a comfortable and firm grip of the lever and knob during braking. Loosen the screw (Ref. S - Figure 11) and rotate the brake lever to the desired position. Check that you have tightened the screw correctly before using the pedal assisted bicycle.

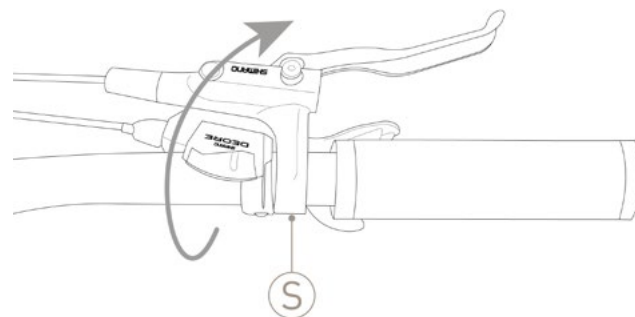

FIG. 11

6.2.6 Regulation of the suspensions

At this point, adjust the suspension to make use of the pedal assisted bicycle more comfortable.

Depending on the route and the load weighing on the vehicle, it is possible to vary the stiffness of the fork using a special lever located on the left side of the fork (Ref. Q - Figure 10.1). The blue handle positioned at the top right (Ref. P - Figure 10.1), on the other hand, allows you to block the compression effectively transforming the suspension from cushioned to rigid. Furthermore, it is possible to adjust the return speed of the suspension itself by turning the red knob positioned in the lower right part of the fork (Ref. R - Figure 10.2).

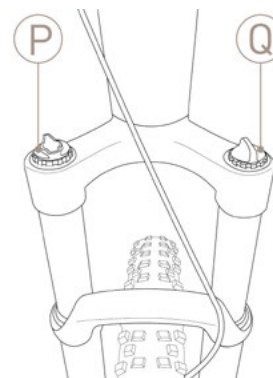

FIG. 10.1

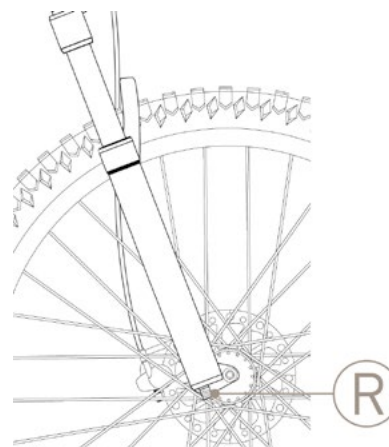

FIG. 10.2



REGULATION

It is strictly forbidden to adjust the bicycle devices unless you are expert and instructed to do so. An incorrect adjustment can cause injuries, even you. Therefore, if you are unable to adjust these functions, contact specialized personnel.

The manufacturer is not liable for injuries deriving from incorrect adjustment of the bicycle devices pedal assisted.

7. USE OF THE BICYCLE

The pedal assisted bicycle has been designed and built for use in open places, with asphalt or similar surfaces, for amateur use.

- It can only be used by experienced adults and children;
- The use of the pedal assisted bicycle is not recommended for pregnant women;
- Do not take alcohol or drugs before riding the pedal assisted bicycle;
- Do not ask the pedal assisted bicycle to perform in excess of what it was designed for. Only use the bicycle in the manner and intended use described in this manual;
- Never ride the pedal assisted bicycle with parts disassembled;
- The pedal assisted bicycle cannot be used on very wet, icy or slippery surfaces;
- Avoid very uneven surfaces and obstacles;
- Ride with both hands on the handlebars;
- Replace worn and/or damaged parts. Eventually, if necessary, have it checked by authorized personnel;

Before leaving, carry out all the checks indicated in the previous chapter and always keep concentrated while driving, for your own safety and that of others.



DANGER

RISK OF INJURY

- **Verify that all the controls are perfectly functional;**
- **Always respect the highway code;**
- **Use the appropriate protective equipment (helmet, etc.)**



7.1 Riding the bicycle

Before using the pedal assisted bicycle in places open to traffic, familiarize yourself with the behaviour of the vehicle. The first uses must be made in private environments away from traffic, other cyclists and obstacles of any kind. The driver must adapt the speed of the pedal assisted bicycle to the road conditions and the presence of other vehicles or pedestrians. Above all when negotiating curves, a moderate speed must be maintained (the smaller the radius of the curve, the lower the speed must be). When the rider stops pedaling or the speed reaches 25 km/h, the electric motor no longer provides assistance and the bicycle proceeds completely managed by the pedals. It is essential to gain experience in riding a pedal assisted bicycle before proceeding at high speed. If you don't want to use the motor, simply remove the battery or set the lowest level of assistance.

7.2 Braking

To reduce the stopping distances of the vehicle to a minimum, it is necessary to stop pedaling abruptly and then apply braking force gradually so as not to destabilize the vehicle.

Encourage the use of the rear brake when braking to stabilize the bicycle.



DRIVING CONDUCT

Excessive braking force can trigger harmful phenomena such as wheel locking or vehicle overturning. It is very dangerous to brake when cornering: you could lose control of the bicycle.

ATTENTION

7.3 Bicycle parking

The bicycle is equipped with a side-type support stand, therefore, before leaving the bicycle, check that the stand is fully extended and resting on stable ground.

The bicycle must be parked in the designated parking areas and, in any case, without obstructing passageways, emergency exits, electrical panels and fire stations.



8. MAINTENANCE



DANGER

RISK OF INJURY

During all maintenance work, follow the appropriate safety measures. All maintenance operations must be carried out with the battery disconnected from the pedal assisted bicycle and from the battery charger; the bicycle must be placed in a stable manner using special support elements.

8.1 Generalities

To maintain full functionality of your pedal assisted bicycle for a long time, it is necessary to carry out maintenance as described, with correctness and professional skills.

After each ordinary maintenance intervention, a check on the perfect functioning of all the controls is mandatory.

8.2 Maintenance and daily checks

8.2.1 Checking plates and pictograms

Check the legibility and presence of the CE plate, and of the warning stickers applied to the bodywork of the bicycle.

8.2.2 Check of the wheels

Using the special inflating valve on the rims, check the inflation pressure of the tires using a compressor and a gun with a pressure gauge, or a pump.

Check the condition of the tread, the rim and the fastening of the rims to the hubs.

If you need to replace the tyres, contact your authorized dealer or a qualified tire specialist.

8.2.3 Check of the brakes

The brakes must be adjusted to ensure effective braking and, at the same time, the control levers must have an adequate stroke to be able to modulate the braking: in other words, the brakes must not be too slow or too tight.

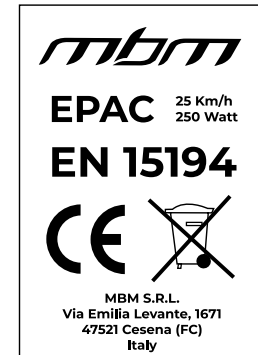

ATTENTION

Do not inflate the tires beyond the admissible value indicated by the manufacturer on the side surface of the same.



ATTENTION

Brake adjustments should only be performed by authorized personnel.



8.3 Maintenance and weekly checks

8.3.1 Washing and cleaning

The cleaning of the pedal assisted bicycle is not only a matter of decorum, but also allows you to immediately detect any defect of the same.

To avoid damaging or compromising the functioning of the various components, especially the electrical parts, cleaning must be carried out taking certain precautions. It is absolutely forbidden to direct jets of pressurized water towards the electrical parts, the motor and the battery, for which washing with a sponge is recommended.

Before starting the pedal assisted bicycle, dry it completely with low pressure compressed air and check that there is no residual humidity on the electrical components.

8.3.2 Lubrification and chain check

It is important to clean and lubricate the chain periodically to avoid corrosion due to atmospheric agents.

1. Clean the entire length of the links with a rag.
2. Spray all links with a suitable spray grease for drive chains.

Check the correct tension of the chain by placing the gear in the two different extreme positions allowed by the rear sprocket.



CORRECT LUBRIFICATION OF THE CHAIN
Be extremely careful not to get the lubricant on the brakes or tires of the bicycle. This can lead to serious injuries!

8.3.3 Check of the frame and bolts

The supporting frame of the pedal assisted bicycle and the welds must be free from visible defects such as: cracks, deformation, incisions, corrosion, etc.

Make sure that all bolts of the pedal assisted bicycle are well tightened.



8.4 Maintenance and monthly checks

8.4.1 Check of the circuits and electronic components

Check the condition and fastening of the battery cables: the electric cable sheaths must be in good condition and the terminals must be well tightened, not corroded and, if necessary, covered with specific protective and insulating grease. Check that all bulbs and warning lights come on correctly.

8.4.2 Check and regulation of the derailleur

Adjustment of the lower and upper limit switches of the rear derailleur: Turn the two screws (Ref. U-T- Figure 12) so that the chain does not come out. The chain shifter should be in line with both the largest and smallest cog. (Ref. Figure 13)

Regulation inferior limit

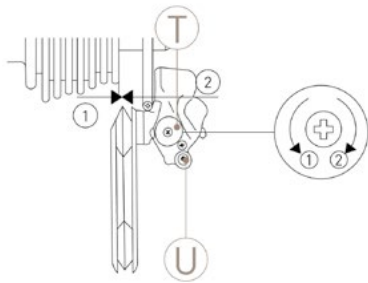

FIG. 12

Regulation upper limit

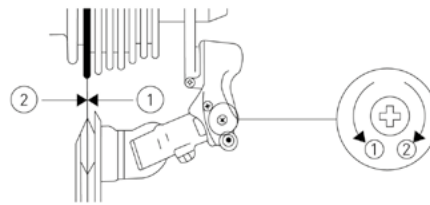

FIG. 13

Adjust the tension of the cable by acting on the specific control to guarantee the immediate response of the rear derailleur to the control of the small lever on the handlebar. (Ref. Figure 14).

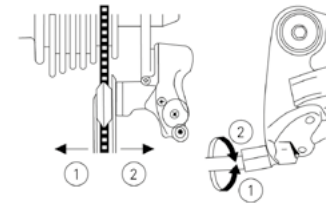

FIG. 14

To prevent damage to the gearbox, it is recommended not to exert too much pressure on the pedals while changing gear. So avoid shifting when exerting effort or driving on slopes.



9. TECHNICAL ASSISTANCE AND SPARE PARTS

If you need technical assistance, contact your authorized dealer.
In case of installation of non-original parts, the guarantee becomes void!



ORIGINAL REPLECEMENT

The manufacturer declines all responsibility for damages of any kind caused by the use of non-original spare parts.

ATTENTION

10. DEPOSIT TO WAREHOUSE

In the event that the pedal assisted bicycle has to be stored and stored for long periods of inactivity, the following operations must be carried out:

- Repair it in a dry and ventilated place;
- Carry out a general cleaning of the pedal assisted bicycle;
- Remove the battery from its seat and place it in a suitable storage site (fully charged and recharged regularly);
- Leave the bicycle on a special support;
- Protect exposed electrical contacts with antioxidant products;
- Grease all surfaces not protected by paint or anti-corrosion treatments.



11. DISPOSAL OF COMPONENTS AND MATERIALS



ATTENTION

DISPOSAL OF MATERIALS

The disposal of packaging, waste and vacuumed dust, of replaced parts and/or of the pedal assisted bicycle as a whole at the end of its expected life, must be carried out with respect for the environment, avoiding polluting the soil, water and air, respecting in all case the national and local legislation in force on the matter.

Indications for waste treatment:

- Ferrous materials, aluminium, copper: these are recyclable materials to be taken to a specific authorized collection centre;
- Plastic materials, fibreglass, gaskets, tyres: these are materials to be sent to landfills or to a specific recycling centre;
- Batteries must be taken to authorized disposal centres.

Divide the materials according to their nature, appointing specialized companies authorized to dispose of them, in compliance with the provisions of the law.

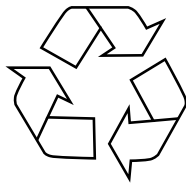

12. WARRANTY STANDARDS

M.B.M. S.r.l. Unipersonale guarantees that its bicycles are free from any manufacturing or workmanship defect. This warranty covers the repair or replacement of any part recognized as defective, subject to the following conditions.

TERMS AND CONDITIONS

- Guarantee period: the pedal assisted bicycle is guaranteed for 24 months on the mechanical and electrical parts, except for the batteries and all the components subject to wear. The batteries are covered by a 24-month limited warranty for correct use of the same:

- first 6 months 100% coverage;
- from the 7th to the 12th month, 50% coverage;
- from the 13th to the 24th month, 25% coverage;

If the battery has been left to discharge below the permitted limit, the manufacturer is not liable for any damage.

- In order to make this guarantee effective, you must fill in the online form which can be accessed via QR CODE or by connecting directly to the website warranty.mbmbike.it no later than 15 days from the date of purchase of the bicycle. You will need the serial number and photo proof of purchase from the authorized reseller. The serial number is printed on the label located in the battery slide and on the battery itself (Figure 15);
- Claims must be made through an official reseller by presenting the original tax document (receipt or invoice) and a printout of the guarantee activation confirmation that you will receive by e-mail after completing the online form.
- The warranty provides for the free replacement of any defective or prematurely worn parts provided that all the prescriptions have been respected and improper use of the bicycle is not found. The manufacturer's obligations are limited to the replacement of defective parts.
- Finally, our Technical Department will decide whether or not the defective part or bicycle falls within the conditions of this guarantee.
- This warranty does not in any way cover the replacement of parts worn by normal use of the bicycle.
- This guarantee does not apply in any case to failures or damages caused by improper use of the bicycle, use of the bicycle for sporting competitions, by the application of non-original accessories, or by improper maintenance interventions.

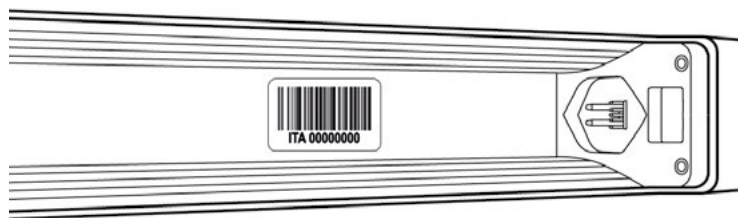

FIG. 15



ACTIVE HERE

YOUR WARRANTY



EXCLUSIONS

Normal wear and tear on parts subject to it, such as tyres, chains, brakes, cables and sprockets in situations where there are no material defects.

- Bicycles serviced by an unauthorized MBM distributor;
- Changes from the original packaging;
- Use of the bike for abnormal activities, such as competition and/or commercial activities, or for purposes other than those for which the bike was designed;
- Damage caused by failure to observe the user manual;
- Damage to paintwork or decals as a result of exposing the bike or riding it in harsh conditions and climates;
- Labor costs for the replacement of parts;
- Transportation fee.

Except as provided in this warranty and subject to all other warranties, MBM and its employees and agents shall not be liable for any loss or damage of any kind (including incidental or consequential loss or damage caused by negligence or default) arising out of or relating to any MBM bicycle.

The M.B.M. S.r.l. does not assume responsibility for damage to property and persons due to improper use of the vehicle.

13. CONFORMITY

Hybrid-drive bicycles with a maximum support speed of 25km/h fulfill the requirements:

- 2006/42/EC Machinery Directive;
- 2014/30/EU Electromagnetic Compatibility Directive;
- 2011/65/EU Rohs Directive

These bicycles also comply with the following non-harmonised standards:

- **Electric bicycles: EN 15194**

Disclaimer:

We strongly recommend that you do not remove or replace any original equipment or modify your bicycle in any way that could change its design and/or function. Such modifications could seriously damage the handling, stability and other aspects of the bicycle, making it unsafe. The removal or modification of parts, or the use of non-original equipment as spare parts, can render the bicycle no longer compliant with applicable standards and laws.

To guarantee safety, quality and reliability, use only original parts or MBM authorized spare parts for repair and replacement.





M.B.M. S.r.l. Unipersonale

Via Emilia Levante, 1671/73/75 | 47521 Cesena (FC)

Tel.: + 39 0547 -300364

Fax: +39 0547-304326

Email: info@mbmbike.it



W W W . M B M B I K E . I T