

KAIROS SUB

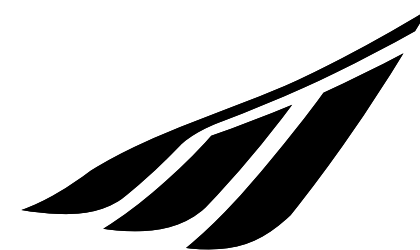

MTB®

USER MANUAL

KAIROS SUB 27,5"

INDEX

1. FOREWORD	4
1.1 General	4
1.2 Assistance	4
1.3 Graphic form of safety warnings	4
2. SAFETY WARNINGS	5
2.1 General safety rules	5
2.2 Liability	5
2.3 Warnings for users	6
2.4 Maintenance warnings	6
2.5 Other provisions	7
2.6 Unpacking and setup	7
2.6.1 Saddle adjustment	7
2.6.2 Pedal assembly	8
3. DESCRIPTION OF THE BICYCLE	9
3.1 General description	9
3.2 Data sheet	10
3.3 Brake levers	11
3.4 Speed change	11
3.5 Assistance system management	12
3.5.1 Assistance management commands	12
3.5.2 Turning the system on / off	12
3.5.3 Activation of Assistance	13
3.5.4 Setting the assistance level	13
3.6 Graphic display interface	14
3.6.1 General screen composition	14
3.7 On-board computer mode	15
3.7.1 Race mode	15
3.7.2 Summary mode	16
3.8 Walk assistance mode	17
3.9 Menu	18
3.9.1 Screen brightness	19
3.9.2 Change language	19
3.9.3 Units of measurement	20
3.9.4 Weight	20
3.9.5 Gender	20
3.10 Error code	21
3.10.1 Troubleshooting	22
3.11 Battery	23
3.11.1 State of charge	23
3.11.2 Battery installation / removal	23
3.11.3 Battery charging	25
3.11.4 Troubleshooting	25
3.12 Front and rear light	26
3.13 front suspension	26
4. TERMS OF USE AND ENVIRONMENT PROVIDED	27
4.1 Intended Use	27
4.2 Environment of use	28
4.3 Improper uses and contraindications	28
5. LIFTING AND TRANSPORT	29
5.1 Lifting	29
5.2 Transportation	29
6. COMMISSIONING	30
6.1 Charging the battery	30
6.2 Preliminary functional checks	31
6.2.1 Control devices	31



6.2.2	<i>Wheels</i>	31
6.2.3	<i>Braking system</i>	31
6.2.4	<i>Frame, handlebar and saddle position</i>	32
6.2.5	<i>Brake adjustment</i>	33
6.2.6	<i>Suspension adjustment</i>	33
6.2.7	<i>Lights operation</i>	33
7.	USE OF THE BICYCLE	34
7.1	Use of the bicycle	35
7.2	Braking	35
7.3	Bicycle parking	35
8.	MAINTENANCE	36
8.1	General	36
8.2	Maintenance and daily checks	36
8.2.1	<i>Checking labels and pictograms</i>	36
8.2.2	<i>Checking the wheels</i>	36
8.2.3	<i>Check brake operation</i>	36
8.3	Maintenance and weekly checks	37
8.3.1	<i>Washing and cleaning</i>	37
8.3.2	<i>Lubrication and chain tension control</i>	37
8.3.3	<i>Checking the frame and bolts</i>	37
8.4	Maintenance and monthly checks	38
8.4.1	<i>Checking and adjusting the front derailleur</i>	38
9.	TECHNICAL ASSISTANCE AND SPARE PARTS	39
10.	STORAGE IN WAREHOUSE	39
11.	DISPOSAL OF COMPONENTS AND MATERIALS	40
12.	WARRANTY RULES	41
13.	COMPLIANCE	42



1. FOREWORD

1.1 General

This manual is an integral and essential part of the pedal assisted bicycle models KAIROS SUB 27.5 ". Before putting it into operation, it is essential that users read, understand and scrupulously follow the following instructions.

The manufacturer is not liable for damage caused to people and / or things or to pedal assisted bicycles, if they are used incorrectly with respect to the prescriptions indicated.

With a view to continuous technological development, the manufacturer reserves the right to modify the components, including the frame without notice, without this manual being automatically updated.

1.2 Assistance

For any inconvenience or request for clarification, contact the authorized dealer, who has competent and specialized personnel, as well as specific equipment and original spare parts.

1.3 Graphic form of security warnings

To identify the safety messages in this manual, the following graphic warning symbols will be used. They have the function of attracting the attention of the reader / user for the purposes of a correct and safe use of the pedal assisted bicycle.



ATTENTION

It highlights behavioral rules to keep in order to avoid damage to the pedal assisted bicycle and / or the onset of dangerous situations.



DANGER

It highlights the presence of dangers that cause residual risks to which the user must pay attention in order to avoid injury or material damage.

2. SECURITY WARNINGS



ATTENTION

USE OF THE PEDAL ASSISTED BICYCLE

Each user must first have read the instruction manual, in particular the chapter on safety information.



ATTENTION

RISKS ASSOCIATED WITH THE USE OF THE PEDAL-ASSISTED BICYCLE

- **Despite the application of safety devices, for safe use of the pedal assisted bicycle, you must take note of all the provisions relating to the prevention of accidents contained in this manual.**
- **Always remain focused while driving and DO NOT underestimate the residual risks associated with the use of pedal assisted bicycles.**

Even if you are already familiar with the use of pedal assisted bicycles, you must follow the instructions given here, in addition to the general precautions to be observed while driving a motor vehicle. In particular:

- Acquire full knowledge of the pedal assisted bicycle.
- Read the manual carefully to learn about the operation, the safety devices and all the precautions necessary for the safe use of the vehicle. All this to allow safe use.
- Carefully keep the pedal assisted bicycle in perfect working order.

For any inconvenience or request for clarification, please contact the authorized dealer without hesitation, who has competent and specialized personnel, specific equipment and original spare parts.

2.2 Responsibility

Failure to comply with the operating instructions and safety prescriptions contained in this manual exempts the manufacturer from any liability.

If the maintenance of the pedal assisted bicycle is carried out in a way that does not comply with the instructions provided, with non-original spare parts or in any case in such a way as to compromise its integrity or modify its characteristics, the manufacturer will be relieved of any responsibility relating to the safety of persons. and malfunction of the pedal assisted bicycle.





ATTENTION

NOT AUTHORIZED USAGE

If you hear unusual noises, or feel something strange, stop the pedal-assisted bicycle immediately. Then carry out a check and, if necessary, contact the authorized dealer.

For each data understood or not deductible from this manual, it is recommended to consult the authorized reseller directly.

2.3 Users warnings

1. It is forbidden to carry a passenger.
2. It can only be used by experienced adults and children.
3. Do not take alcohol or drugs before riding the pedal assisted bicycle.
4. These pedals assisted bicycle models are designed and built to be used outdoors, on roads and private and public environments.
5. Do not ask the pedal assisted bicycle to perform better than that for which it was designed.
6. Never ride the pedal assisted bicycle with parts that have been disassembled.
7. Drive with both hands on the handlebar.
8. Replace worn and / or damaged parts, check that the protections work correctly before use.

2.4 Maintenance

1. All maintenance operations must be carried out with the battery disconnected.
2. During each maintenance phase, operators must be equipped with the necessary accident prevention equipment.
3. The tools used for maintenance must be suitable and of good quality.
4. Do not use gasoline or flammable solvents as cleaning agents, but always use non-flammable and non-toxic solvents.
5. Limit the use of compressed air for cleaning as much as possible (max 2 bar) and protect yourself with goggles with side shields.
6. Never resort to the use of open flames as a means of lighting when carrying out inspection or maintenance operations.
7. After any maintenance or adjustment operation, make sure that no tools or foreign bodies are left between the movement parts of the pedal-assisted bicycle.



ATTENTION

ORIGINAL SPARE PARTS

**Use only original spare parts supplied by M.B.M. S.r.l.
Any liability of the Manufacturer for damage or loss of functionality caused following the use of non-original accessories and parts is excluded.**



2.5 Others

The first thing to do when starting use is to check the presence and integrity of the protections and the operation of the safety devices. If you find any defects, do not use the pedal assisted bicycle!



DANGER

SPARE PARTS

It is strictly forbidden to modify or remove the guards, controls, labels and information plates.

2.6 Unpacking and tuning

The pedal assisted bicycle is delivered fully assembled and in working condition.

2.6.1 Saddle

Adjusting the height of the saddle is an essential prerogative for the correct use of the pedal assisted bicycle. Incorrect adjustment can generate structural breaks in the frame.

Adjust the height of the saddle using the screw placed in the collar (Ref. A - Figure 1).

Check that the mechanism is tightened before testing the seat and using the vehicle. Do not tighten the collar screw (Ref. A - Figure 1) beyond the maximum value of 8 Nm. Do not lift the saddle beyond the limit switch signal placed in the stem (Ref. B - Figure 1).

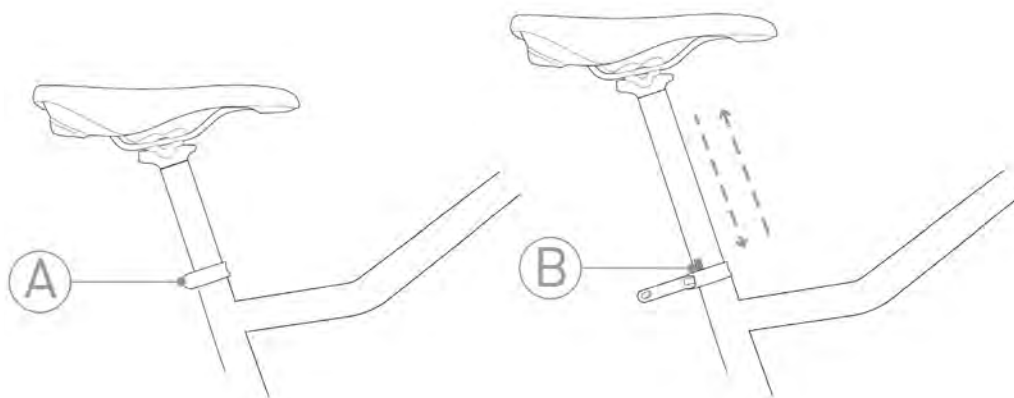

FIG. 1



DANGER

IMPORTANT:

For your safety, the seatpost reference mark (B) should never be outside the tube into which the seatpost is inserted.



ATTENTION

ASSEMBLY

In the event that you do not have the appropriate instrumentation for adjustment or do not have the skills, contact the authorized dealer.



2.6.2 Pedal assembly

Right Pedal: it is identified by the letter R marked on its pin.
To assemble the pedal, screw it by turning the pin clockwise.
(Figure 2)

Left Pedal: it is identified by the letter L marked on its pin.
To assemble the pedal, screw it by turning the pin counter-clockwise.
(Figure 2)



ATTENTION

ASSEMBLY

In the event that you do not have the appropriate tools for adjustment or do not have the skills, contact the authorized dealer.

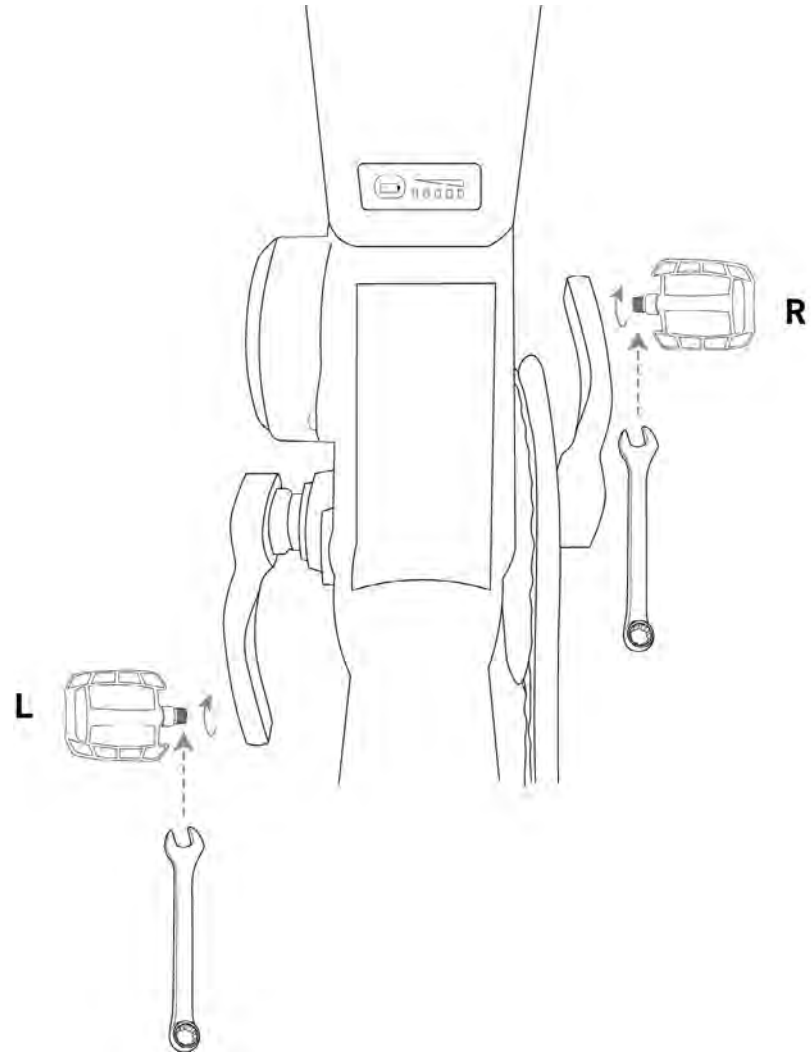

FIG. 2

3. DESCRIPTION OF THE BICYCLE

3.1 General description

The pedal assisted bicycle is designed and built to be used outdoors, on roads and private or public environments. In particular, the components and the type of pedal assisted bicycle allow you to tackle routes with asphalted and dirt surfaces without particular roughness.



NOT ALLOWED USAGE

The bicycle was designed and built for the specified use; a different use and non-compliance with the technical parameters set by the manufacturer may constitute a dangerous condition for users.

The pedal assisted bicycle is equipped with a rechargeable battery and an electric motor, whose intervention takes place only in conjunction with the pedaling and progressively stops as the vehicle speed approaches 25 km / h, and then comes to a complete stop. at that speed.

To manage the assistance system there is a special control located next to the left grip on the handlebar.

On the right side of the handlebar there is a control system for selecting the gears.



3.2 Technical sheet

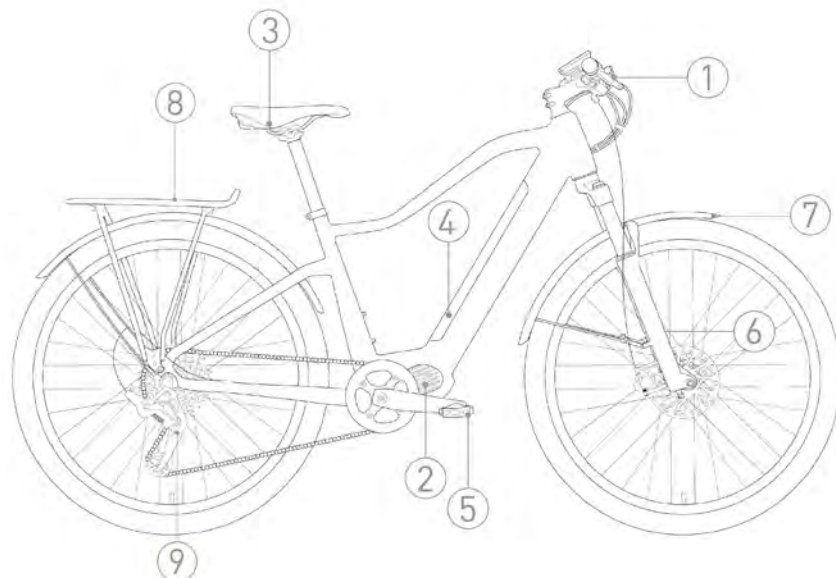

1. HANDLEBARS AND CONTROLS
2. MOTOR
3. SADDLE
4. BATTERY
5. PEDALS
6. FORK
7. MUDGUARDS
8. REAR CARRIER
9. REAR DERAILLEUR

CODE	E1220SUB
FRAME	ALUMINIUM HYDROFORMED
FORK	SUSPENSION WITH ADJUSTMENT
CRANK SET	36 TEETH
REAR DERAILLEUR	DEORE
SHIFTER	11 SPEEDS
BRAKES	SHIMANO BR-M315 HYDRAULIC
WHEELS	SHIMANO ANT: Ø 180 mm POST: Ø 180 mm
TYRES	27,5X2.60
SADDLE	SADDLE ITALIA X3
PEDALS	RIGHT-HANDED AND SINISTER STEEL IN POLYMER MATERIAL
ENGINE	OLI SPORT 85 NM
BATTERY	PHYLION BN-18, 14 Ah, 504 Wh
SPEED* MAX. ASSISTANCE	25 KM/H
DISPLAY	LCD
POWER LEVELS	5
WEIGHT	22 KG



3.3 Brakes

The brake levers (Ref. C - Figure 3) are located on the handlebar of the pedal assisted bicycle, near the knobs (Ref. D - Figure 3). These systems allow you to check the calipers of the brake discs, located near the wheel hubs. The right lever controls the rear brake, the left lever controls the front brake; the braking action is proportional to the force applied to the lever.

3.4 Speed

The pedal assisted bicycle has an 11-speed gearbox with the sprockets positioned on the rear wheel hub, selectable using the opposing levers, located at the base of the right knob. The indicator (Ref. E - Figure 3) present in the upper part of the handlebar allows you to view the selected ratio.

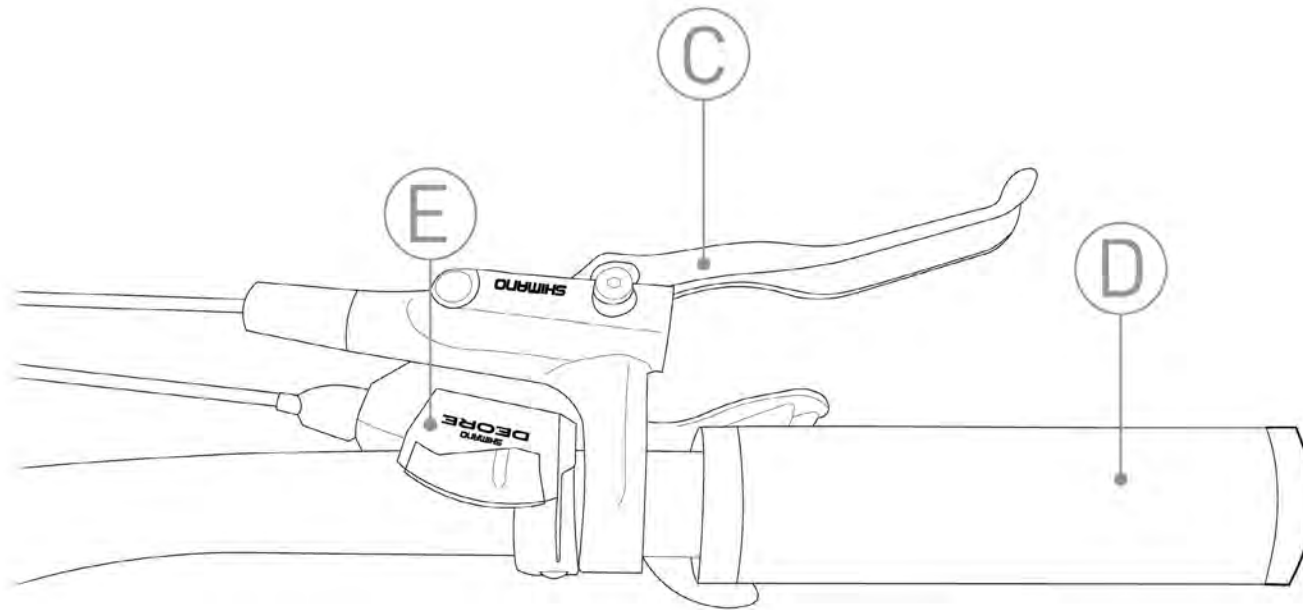

FIG. 3

3.5 Assistance warning

3.5.1 Commands

The pedal assisted bicycle has, in the center of the handlebar, a display that allows you to manage the operation of the electric motor, as well as other basic functions illustrated below. (Figure 4)

Near the left handlebar grip there are 3 keys, which can be used with a short or long press, thanks to these it is possible to control the display functions. (Figure 5)



FIG. 4

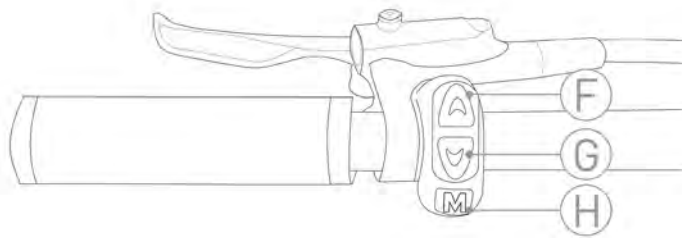

FIG. 5

button	Short pressure/ <1 second	prolonged pressure/ > 2 seconds
H-power	Allows you to: Scroll through the Home from one Main Screen to another; Scroll between Home and Menus; confirm the action during the changes.	Allows you to: Turn the display on and off; from the Menu and Advanced section, return to the last Home screen displayed.
F-up	Allows you to scroll through menu items, going up. allows you to increase the level of assistance.	from any main screen allows you to change the mode of operation of the lights.
G-down	allows you to scroll through menu items, going down. allows you to reduce the level of assistance.	from any main screen allows you to activate the Walk mode
F+G down+up	-	from the main screens, the simultaneous press of the two buttons, allows you to access the menu.

3.5.2 System on/off

To activate the system, press the "POWER" button (Ref.H - Figure 5) until the power on screen is displayed or press the "ON" button on the battery. To turn off the display, press and hold the "POWER" button until the shutdown screen appears or press the "OFF" button on the battery. If the E-Bike is not used for a variable time depending on the type of battery, the system will turn off automatically.



3.5.3. Activation of the assistance

The thruster is activated, and is immediately deactivated if pedaling stops. The power of the engine depends on the force impressed on the pedals, according to a multiplicative factor depending on the level of assistance selected.

3.5.4 Level of assistance

From any screen in the Home section it is possible to change the assistance level by pressing the "UP" key (Ref. F - Figure 5) to increase it and the "DOWN" key (Ref. G - Figure 5) to decrease it.

LEVEL 0 - NO ASSISTANCE

LEVEL 1 - ASSISTANCE 12.5%

Recommended route : plain - long distance

LEVEL 2 - ASSISTANCE 25%

Recommended route : plain/hilly - medium to long

LEVEL 3 - ASSISTANCE 50

Recommended route : hilly/medium ascent - medium distance

LEVEL 4 - ASSISTANCE 75%

Recommended route : ascent - short distance

LEVEL 5 - 100% SUPPORT

Recommended route : challenging ascent - short route

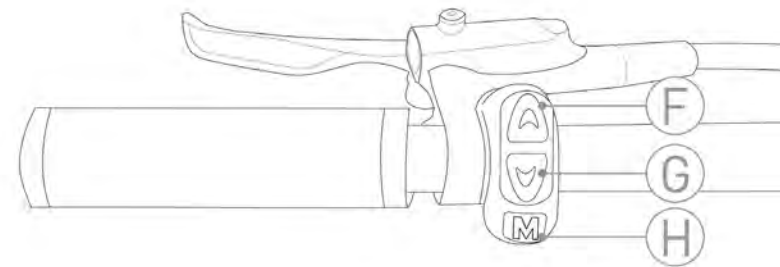

FIG. 5



ATTENTION

ATTENTION:

The engine has 5 levels of assistance which increase the power delivered by the engine. If you set it to 0, the motor is switched off.

3.6 Display

After switching on, the first Distance screen of the Home section is displayed. The Home section consists of 6 screens. To scroll through the screens it is necessary to press the "POWER" button.

From any screen in the Home section, you can:

- ›Adjust the level of assistance by pressing the" UP "and" DOWN "keys;
- ›Enter Walk mode by holding down the" DOWN "key;
- ›Adjust the brightness of the eBike lights by holding down the" UP "button for 2";
- ›Enter the Menu section, holding down the" UP "+" DOWN "keys at the same time for 2".

3.6.1. Display screening

The screens in the Home section differ from each other in the type of information displayed. (Figure 4.1)

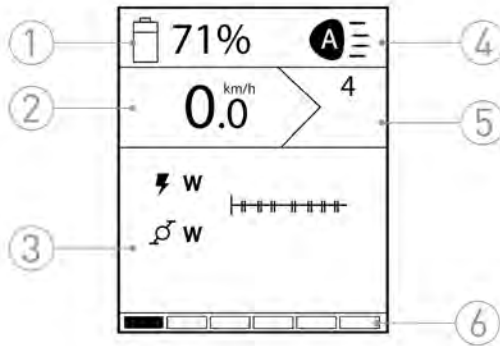

FIG. 4.1

1- BATTERY

-CHARGE STATUS PERCENTAGE.

2- E-BIKE CURRENT SPEED

IN KILOMETERS/HOUR (KM/H).

3- POWER GRAPHICS DISPLAY

-UPPER BAR: ENGINE POWER,
- LOWER BAR: CYCLIST POWER.

4- E-BIKE LIGHT ADJUSTMENT

AUTOMATIC/ON/OFF(RIF.3.7)

5- SERVICE LEVEL

(RIF. 3.5.4)

6- NAVIGATION BAR

PRESENT ON EACH SCREEN, INDICATES THE CURRENT SCREEN.



ENGINE POWER



CYCLIST POWER



DISTANCE TRAVELLED FROM THE START OF THE LAP



TIME ELAPSED SINCE THE START OF THE TOUR



PEDAL CADENCE



ENERGY BURNED BY THE CYCLIST



AVERAGE CONSUMPTION E-BIKE



TOTAL DISTANCE



TRAVELED AVERAGE SPEED



3.7 On-board computer mode

The on-board computer is able to adapt to different usage scenarios, from commuting to sports use. To switch between the available display modes, briefly press the "POWER" button (Ref. H - Figure 5).

3.7.1. Mode "RACE"

It is the fifth screen of the Home section.

In this screen, the values in watts (w) of the motor power and cyclist power are expressed in full. (Figure 4.2) This mode of use is addressed to expert users, and to a sporty use of the e-bike. (Figure 4.2)

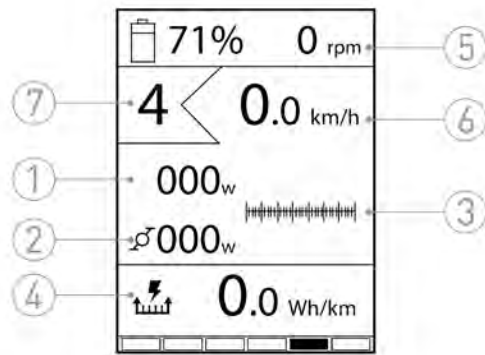

FIG. 4.2

1- POWER



Indicates the instantaneous power delivered by the motor in watts (w).

2- CYCLIST POWER



Indicates the instantaneous power expressed by the cyclist in watts (w).

3- POWER DISPLAY



Graphic display of the upper bar power: engine power lower bar: cyclist power.

4- ENERGY CONSUMPTION



Indicates the average energy consumption in watt-hours per kilometer (Wh/km), calculated since the last zeroing.

This data allows to adjust the level and five of the consumption of the eBike according to the need.

By calculating the ratio between this data and the capacity of the battery, the exact possible mileage data for each charge is obtained.

5- CADENCE

6- CURRENT SPEED

7- SERVICE LEVEL

$$\frac{\text{battery capacity}}{\text{average consumption}} = \text{Passable km}$$



3.7.2. Review

It is the sixth screen of the Home section.

This screen summarizes the variable parameters of the previous screens. (Figure 4.3)



FIG. 4.3

1- INDICATES THE DISTANCE TRAVELED IN KILOMETERS (KM) SINCE THE LAST RESET.

2- INDICATES THE TIME SPENT IN MOTION SINCE THE LAST RESET.
THE VALUE IS EXPRESSED IN HOURS: MINUTES: SECONDS.

3- INDICATES THE AVERAGE SPEED IN KILOMETERS PER HOUR (KM / H) DETECTED SINCE THE LAST RESET.

4- INDICATES THE AVERAGE ENERGY CONSUMPTION IN WATT-HOURS PER KILOMETER (WH / KM), CALCULATED SINCE THE LAST RESET.

5- INDICATES THE ENERGY CONSUMED BY THE CYCLIST IN KILOCALORIES (KCAL) SINCE THE LAST RESET.

6- INDICATES THE TOTAL DISTANCE TRAVELED BY THE EBIKE IN KILOMETERS (KM).
NON-RESETTABLE VALUE.

3.8 Assisted walk

The system is equipped with a walking assistance function, which allows you to activate the engine up to a maximum speed of 6km / h to allow you to tackle short stretches more easily by pushing the e-bike.

To activate the walking assistance function, keep the "DOWN" key pressed (ref. G in Figure 5). The engine will activate, and the appropriate warning will appear on the display. The engine will shut down in the following cases:

- Release of the "DOWN" button (Ref. G in Figure 5)
- Speed above 6km / h
- Locking the e-bike wheel

NOTE: By selecting the assistance level "0", the motor is completely disabled, and it is not possible to use the walk assistance function.



ATTENTION

Walk assistance mode Before activating the walking assistance mode, hold the handlebar firmly to avoid injury.

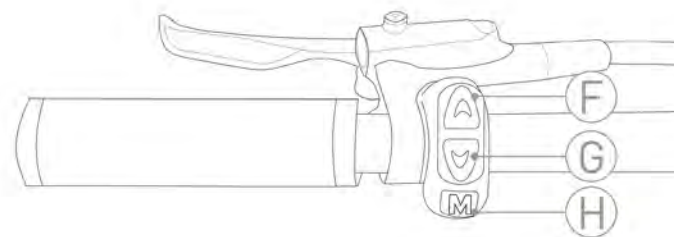

FIG. 5



3.9 Menu

By pressing the "UP"+"DOWN" buttons simultaneously (Ref. F - G - Figure 5) for two seconds you can open the screen of the menu. From any screen, holding the "POWER" key for 2", you can return to the last screen Home displayed. Once entered you can move in the menu with the buttons "UP" and "DOWN" and press "POWER" as sending.



ATTENTION

Before pressing the F and G buttons at the same time (Figure 5), position yourself firmly on the bike and activate the brake, so as not to accidentally activate the starting mode from a standstill.



FIG. 4.4

RESET TRIP

THE RESET TRIP ITEM ALLOWS YOU TO RESET ALL THE RECORDED LAP DATA BY RETURNING THE COUNTERS TO ZERO (0).

ADVANCED

SELECTING THIS FUNCTION YOU ENTER THE ADVANCED SETTINGS MENU.

SYSTEM INFO

IN THIS SCREEN IT IS POSSIBLE TO VIEW THE VERSIONS OF THE FIREWARE, THE INSTALLED HMI AND THE ASSOCIATED ENGINE.

BATTERY INFO

BY SELECTING THIS FUNCTION YOU CAN VIEW THE BATTERY INFORMATION.

BACKARDS

SELECTING THIS FUNCTION RETURNS TO THE INITIAL SCREEN.



By selecting the **ADVANCED** setting, you enter the advanced settings menu, within which you can change or check the essential parameters of the display. Specifically, you can change the brightness, language, unit, weight, gender and night mode.

ADVANCED
Brightness
Language
Unit
Weight
Gender
Night Mode
Back

FIG. 4.5

3.9.1. Screen brightness

From this screen, you can adjust the brightness of the screen. Use the "UP" and "DOWN" keys to scroll between the values from 1 to 10. The selected value is highlighted in the center in the white line. (Figure 4.6)

BRIGHTNESS
4
5
6
7
8

FIG. 4.6

3.9.2. Language change

From this screen you can choose the language of the unit texts. Use the "UP" and "DOWN" keys to scroll through the available items. The selected value is highlighted in the center in the white line. (Figure 4.7)

LANGUAGE
Italiano
English
Français
Deutsch
Español

FIG. 4.7



8.9.3 Units of measurement

From this screen you can select the unit of measurement with which they are calculated:

- > instantaneous speed,
- > average speed,
- > average consumption,
- >Lap distance,
- >Total distance.

Use the "UP" and "DOWN" keys to scroll through the available items. The selected value is highlighted in the center in the white line. (Figure 4.8)

<u>UNIT</u>
Km
Miles
Back

FIG. 4.8

8.9.4 Weight

From this screen you can set your body weight by choosing a value between 50 and 150 kg. Setting this data is not necessary for the correct functioning of the eBike. The value has the sole purpose of making the calculation of calories consumed reliable.

Use the up and down keys to scroll through the available items. The selected value is highlighted in the center in the white line. (Figure 4.9)

<u>WEIGHT</u>
68
69
70
71
72

FIG. 4.9

8.9.5 Gender

From this screen you can set your gender. Setting this data is not necessary for the correct functioning of the eBike. The value has the sole purpose of making the calculation of the calories consumed reliable.

Use the up and down keys to scroll through the available items. The selected value is highlighted in the center in the white line. (Figure 4.10)

<u>GENDER</u>
Male
Female
Back

FIG. 4.10



3.10 ERROR CODE

In the event of an anomaly, the system reports the problem to the user by displaying a danger icon combined with a 4-character code, which allows you to trace the type of error.

Depending on the type of anomaly, the system could prevent the engine from being activated or make it run at reduced power. Where it is indicated "request assistance", the intervention of an OLI eBike Systems technician is required.



attention

Depending on the type of failure, the system may prevent the engine from starting or operating at full power.

ANOMALY CODE	DESCRIPTION
0001	PROBLEM COMMUNICATING WITH BATTERY. BATTERY STATUS DATA MAY BE DISPLAYED INACCURATELY. CHECK THAT THE WIRING AND CONTACTS OF THE BATTERY ARE CONNECTED CORRECTLY AND INTACT.
0101	COMMUNICATION PROBLEM BETWEEN DRIVE AND HMI. CHECK THAT THE WIRING IS CONNECTED CORRECTLY AND INTACT.
0104	SPEED SENSOR NOT DETECTED. CHECK THAT THE ALIGNMENT BETWEEN THE MAGNET AND THE SPEED SENSOR IS CORRECT. CHECK THAT THE SPEED SENSOR IS INSTALLED AND CONNECTED CORRECTLY.
0105	NON-COMPLIANT TORQUE TRANSDUCER SIGNAL. THE TORQUE TRANSDUCER SIGNAL HAS AN ANOMALY. LOW POWER OPERATION.
0106	OFFSET TORQUE TRANSDUCER NOT COMPLIANT. THE TORQUE TRANSDUCER SIGNAL HAS AN ANOMALY.
0801	ANOMALY TO MOTOR ROTATION SENSORS.
0802	PEDAL ROTATION SENSOR ANOMALY.
0804	EXCESSIVE DRIVE TEMPERATURE. THE TEMPERATURE SENSOR HAS DETECTED A TEMPERATURE ABOVE THE THRESHOLD OF DANGER.
0805	EXCESSIVE ENGINE TEMPERATURE. THE ENGINE HAS REACHED A TEMPERATURE ABOVE THE DANGER THRESHOLD.
0806	NON-COMPLIANT PERIPHERAL BUS VOLTAGE.
808	LOCKED ROTORS. THE ENGINE FAILED TO START DUE TO A MECHANICAL BLOCKAGE OR A PROBLEM WITH THE INTERNAL WIRING OF THE DRIVE UNIT.



0809	THE BATTERY VOLTAGE IS HIGHER THAN THE MAXIMUM ALLOWED.
0810	NON-COMPLIANT CURRENT SENSOR SIGNAL.
0811	THE DRIVE DETECTED AN OVERCURRENT.
1101	COMMUNICATION PROBLEM BETWEEN HMI AND DRIVE. CHECK THAT THE WIRING IS CONNECTED CORRECTLY AND INTACT.
1102	A BUTTON PANEL IS LOCKED IN THE PRESSURE POSITION.

3.10 troubleshooting

The following table lists the main problems that can be encountered and the possible solutions to be adopted.

PROBLEM	CAUSE/SOLUTION
THE SYSTEM DOES NOT TURN ON	CHECK THAT THE BATTERY IS PROPERLY INSERTED IN PLACE, AND THAT IT IS CHARGED.
SUPPORT DOES NOT ACTIVATE	CHECK THAT THE SELECTED LEVEL OF ASSISTANCE IS GREATER THAN 0, AND THAT THE LEVEL OF CARI-BATTERY APPROX IS SUFFICIENT.
THE DISPLAY DISPLAYS AN ERROR MESSAGE	THE SYSTEM DETECTED AN ANOMALY. DEPENDING ON THE TYPE OF ANOMALY, THE ENGINE MAY BE DEACTIVATED OR OPERATE AT REDUCED POWER. FOR MORE DETAILS REFER TO CHAPTER 3.10.
THE DISPLAY GLASS IS FOGGED	FOLLOWING SUDDEN CHANGES IN ENVIRONMENTAL CONDITIONS, CONDENSATION IS POSSIBLE INSIDE THE GLASS. CONDENSATE WILL DISAPPEAR AS A RESULT OF TEMPERATURE STABILIZATION.



ATTENTION

If after these operations the problem persists, request support at a service center.



3.11 Battery

The bicycle provides pedaling assistance through an electric motor powered by the battery located in the down tube of the frame structure (Figure 6)

3.11.1 Battery charge status

You can view the battery charge status directly on the assistance system management display.

In the event that the battery is removed from the vehicle or you want to see the state of charge without turning on the assistance system, in the lower part of the battery there is a button (Ref. I - Figure 6) which allows, by means of 5 LED lights (Ref. L - Figure 6), to view the state of charge.



FIG. 6

3.11.2 Battery installation/remotion

To remove the battery, make sure that the assistance system is switched off and proceed as follows:

- 1- Insert the battery lock / release key in the appropriate lock in the upper left part of the frame, near the handlebar and turn the keys counterclockwise (Ref. M - Figure 7);
- 2- Keeping the key turned, release the battery and lift it (Ref.2 - Figure 7).
- 3- Extract the battery completely taking care not to hit the frame.



FIG. 7

To install the battery proceed as follows:

1- This procedure must be performed without the release key, remove it if inserted.

2- Align the battery over the oblique tubing of the frame by first matching the electrical connector (Ref. O - Figure 8).

3- Carefully insert the battery into the frame until you hear the lock click. At this point the battery is already automatically locked.

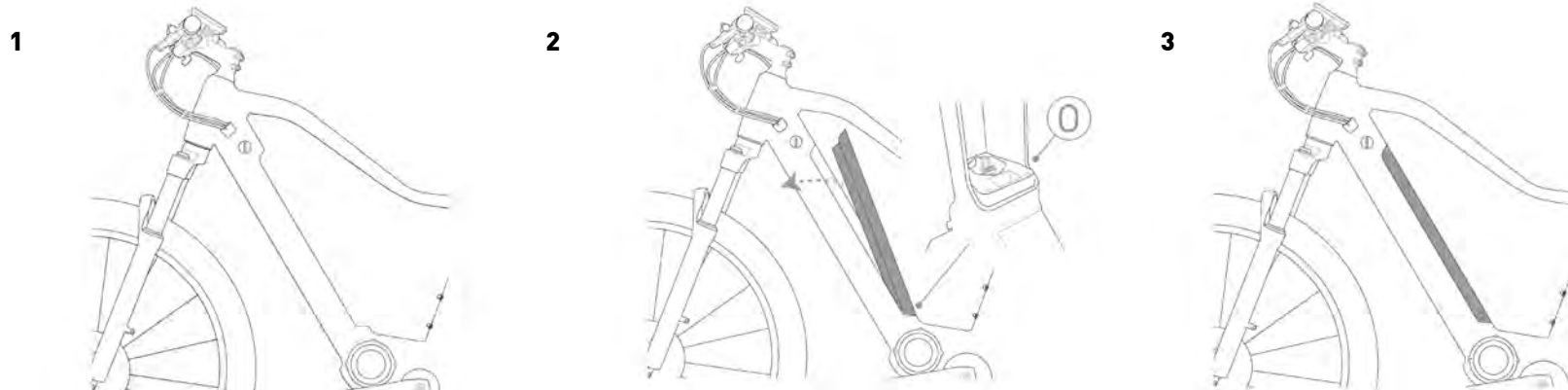
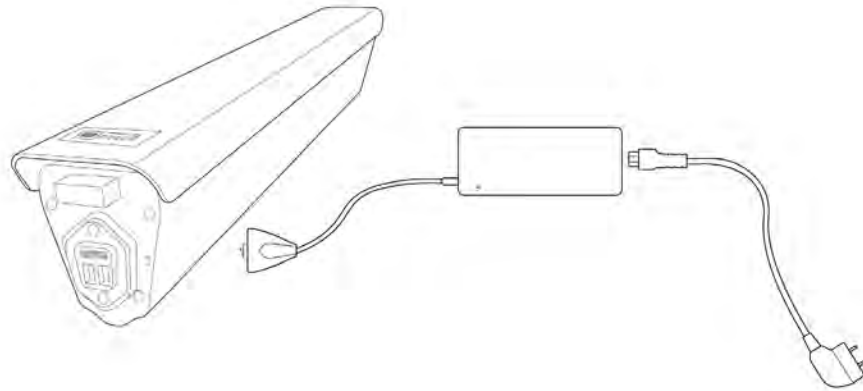

FIG. 8

3.11.3 Battery charge

Recharging the battery of the pedal assisted bicycle can only be done by removing the battery. To charge the battery proceed as follows:

- 1- Turn off the assistance system of the pedal-assisted bicycle using the appropriate "MODE" button (Ref. H in Figure 5);
- 2- Remove the battery;
- 3- Connect the battery charger supplied to the socket with the appropriate plug at the bottom of the battery;
- 4- Connect the battery charger to a power socket (230 V / 50 Hz) and let the battery charge for the necessary time.



CHARGER

Always connect the plug to the battery first and then the battery charger to the power outlet.

FIG. 9

3.11.4 Troubleshooting

PROBLEM	CAUSE/SOLUTION
System doesn't turn on	Check if the battery is full
PROBLEM	CAUSE/SOLUTION
Assistance does not	Check if the level of the battery is sufficient



ATTENTION

PROBLEM SOLVING

In the event that the assistance system does not activate even though the battery is charged, contact the authorized dealer.



3.12 front suspension

The pedal assisted bicycle is equipped with a front suspension system that allows to dampen the stresses caused by the roughness of the path. The suspension model is adjustable by means of special adjustment controls in the upper and lower part of the forks. In particular, it is possible to vary the preload of the forks by rotating the lever in the upper left part (Ref. Q - Figure 10.1) based on the characteristics of the user and the terrain. The blue lever positioned at the top right (Ref. P - Figure 10.1), on the other hand, allows the compression to be blocked, effectively transforming the suspension from amortized to rigid. Furthermore, it is possible to adjust the return speed of the suspension itself by turning the red knob positioned in the lower right part of the fork (Ref. R - Figure 10.2).

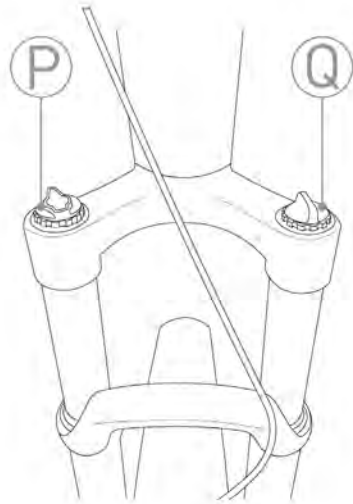

FIG. 10.1



FIG. 10.2

4. USAGE AND ENVIRONMENT REQUIRED

4.1 Usage

The pedal assisted bicycle is designed and built to be used outdoors, on roads and private or public environments. In particular, the components and the type of pedal assisted bicycle allow you to tackle routes with asphalted surfaces or with similar characteristics without particular roughness.

Any modification of the state of construction can compromise the behavior, safety and stability of the pedal assisted bicycle and can lead to an accident.

Other types of use, or the extension of use beyond that envisaged, do not correspond to the destination assigned by the manufacturer, and therefore the same cannot assume any responsibility for any resulting damage.

4.2 Environment

The pedal assisted bicycle can be used outdoors, in the absence of adverse weather conditions (rain, hail, snow, strong wind, etc.):

- Maximum allowed temperature: +40 ° C
- Minimum allowed temperature: 0 ° C
- Maximum permissible humidity: 70%

The environment of use may have an asphalted surface or with not excessively high roughness.

Furthermore, the place of use must be illuminated, by the sun or by artificial lights, in such a way as to ensure the correct view of the path and of the pedal assisted bicycle controls (recommended from 300 to 500 lux). The pedal assisted bicycle can be equipped with front white light and rear red light.



ATTENTION

FORBIDDEN

The pedal assisted bicycle must not be used:

- **In areas subject to risk of fire or explosion;**
- **In environments with a corrosive and / or chemically active atmosphere;**
- **in poorly lit environments;**
- **On excessively rough terrain, given its characteristics (frame, wheels, etc.);**
- **In closed spaces, if they do not allow safe use;**
- **In dark environments.**



4.3 Improper usage

The actions described below, which obviously cannot cover the entire range of potential possibilities of "misuse" of the pedal assisted bicycle, are to be considered absolutely prohibited.



ATTENTION:

FORBIDDEN

- The performance of prohibited operations invalidates the warranty.
- The manufacturer declines all responsibility for any damage to property and people resulting from the execution of prohibited operations



DANGER

ABSOLUTELY FORBIDDEN

- To ride the pedal assisted bicycle for uses other than those for which it was built, that is, the pleasure of a passenger.
- Ride the pedal assisted bicycle in areas where there is a danger of explosions.

DANGER:

- Ride the pedal assisted bicycle in adverse weather conditions (heavy rain, hail, snow, strong wind, etc.).
- Carrying a passenger in addition to the driver.
- Riding the pedal assisted bicycle under the influence of alcohol or drugs.
- Ride the pedal-assisted bicycle if your weight is greater than the permitted weight.
- Charge the battery in an environment that is too hot or not sufficiently ventilated.
- Cover the battery while charging.
- Smoke or use open flames near the charging area.
- Perform any maintenance with the battery connected.
- Use non-original spare parts.
- Insert your limbs or fingers between the moving parts of the bicycle.
- Use the bicycle on asphalted or unpaved terrain with obstacles higher than those permitted by the vehicle.



5. LIFTING AND TRANSPORT

5.1 LIFTING

The weight of the pedal assisted bicycle model KAIROS SUB is such that it can be lifted and carried by one person, also due to its overall dimensions.

The optimal solution for carrying out the movement is to grab a handlebar grip and the rear part of the saddle.



DANGER

CRUSHING AND IMPACT

- **During lifting, you must operate with extreme caution to avoid damage to people and property.**
- **This operation must be performed by sturdy people.**

The manufacturer is not liable for breakages caused by lifting and / or transporting the pedal assisted bicycle after delivery.

5.2 Transport

To ensure the safety of transport in vans, it is necessary to prevent the pedal-assisted bicycle from moving. This is achieved by binding it with anchoring bands or cables in good condition.

In this regard, the coupling devices must be installed in such a way as not to damage the frame and other parts of the bicycle.



DANGER

INJURY RISKS

- **ALWAYS make sure that the frame and handlebar adjustment screws are tightened before each ride. Otherwise, accidents, even serious ones, could result!**



6. COMMISSIONING

6.1 Battery charging

Before using the bicycle for the first time, the battery must be charged for at least 8 hours, using the special battery charger, supplied.

The pedal assisted bicycle, model KAIROS SUB, is equipped with an electric motor powered by a 36 V lithium-ion battery. The battery pack is housed in the central part of the frame, inside the lower tube.

The average charging time varies from 4 to 6 hours.

The recharging operation can be carried out in a well-ventilated box with the battery installed on the bicycle. To charge the battery proceed as in paragraph 3.11.3.

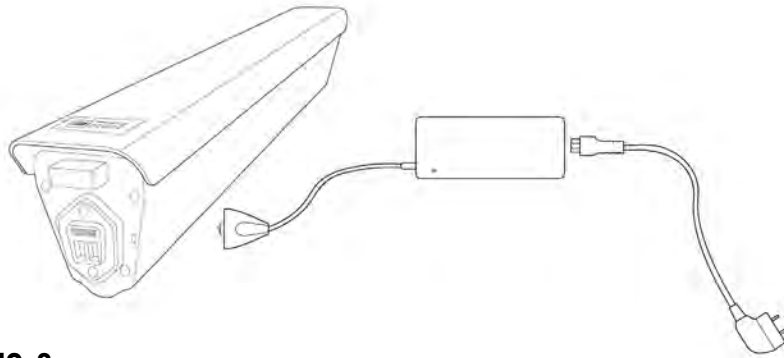

FIG. 9



ATTENTION

CHARGER

Always connect the plug to the battery first and then the battery charger to the power outlet.



ATTENTION

BATTERY LEVEL

preserve its life and not run the risk of damaging it. In any case, it must be recharged at least every 3 months even if the bicycle is not used.



DANGER

CHARGING PRECAUTIONS

- **Always connect the plug to the battery and then the power plug to the mains.**
- **When charging is complete, always disconnect the plug from the mains first and then the plug from the battery.**
- **Always recharge the battery fully.**
- **Always use the original power supply supplied.**
- **Do not leave the battery charging for more than 8 hours.**
- **Always recharge in a ventilated area.**
- **Do not recharge the battery in too hot environments.**
- **Do not recharge the battery near flammable liquids.**
- **Do not cover the battery in any way while charging.**
- **If the battery emits a bad smell, immediately disconnect the plug from the power supply and ventilate the room, do not touch the battery.**



6.2 Preliminary functional checks

Before each use, the driver must check the safety status of the pedal assisted bicycle. Therefore, perform the following inspections before riding the pedal-assisted bicycle.

6.2.1 Commands

Check the efficiency and state of charge of the battery. Use in a very cold environment quickly degrades the efficiency of the battery. Check chain tension and lubrication.

6.2.2 Wheels

Check the tire inflation pressure. Check the state of wear of the tread: there must be no cuts, cracks, foreign bodies, abnormal bulges, visible plies and other damage.



ATTENTION

Do not inflate the tires beyond the allowable value indicated by the manufacturer on the side surface of the tires.

6.2.3 Braking system

Carry out a visual check of the braking system, verifying that there are no damaged cables or lubricants in the braking surfaces of the brake and rim. Check the operation of the brakes with a low-speed braking test in an obstacle-free area, first with the rear brake and then with the front one. Test the efficiency of the braking system on a flat path and at low speed.



ATTENTION

NEGATIVE TEST

In the event that, during the preliminary checks, defects of any kind are found and even a single check is negative, DO NOT RIDE THE BICYCLE WITH ASSISTED RIDING. Immediately take all measures to carry out an adequate repair and, if necessary, contact the authorized dealer or an authorized workshop.



6.2.4 Frame and saddle positions

Check that the frame and saddle are properly secured and positioned in the most comfortable configuration for the rider for complete control of the bike. Otherwise, before setting off, act on the saddle position adjustment systems. For further information on regulation, refer to paragraph 2.6.

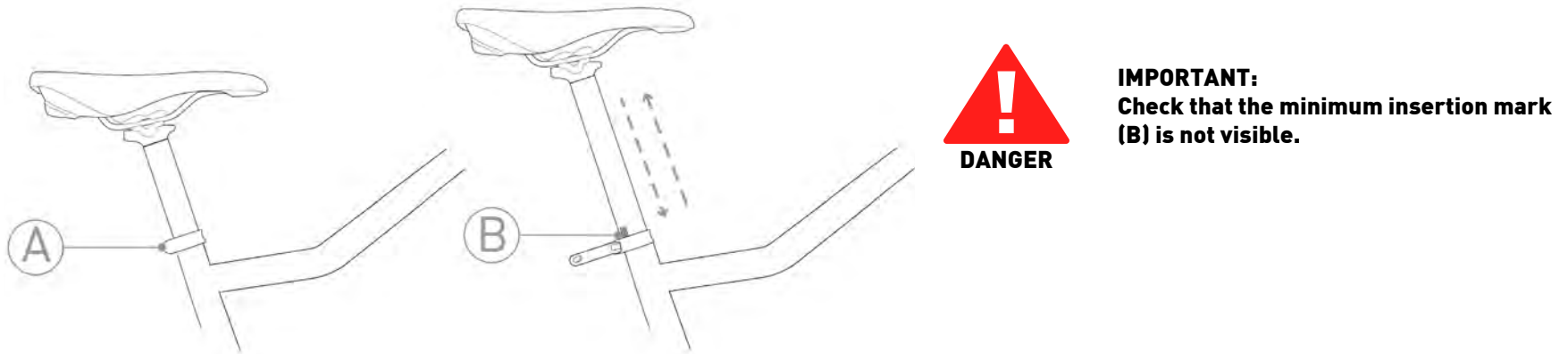

FIG. 1



CHASSIS POSITION

It is strictly forbidden to use the bicycle without having correctly fixed all the parts of the bicycle that were folded and without having assumed a comfortable and safe riding position.



6.2.5 Brakes regulations

Before using the pedal assisted bicycle, adjust the position of the brake levers on the handlebars to obtain a comfortable and firm grip of the lever and grip during braking.

Loosen the screw (Ref. S - Figure 11) and rotate the brake lever to the desired position. Make sure you have tightened the screw correctly before using the pedal assisted bicycle.

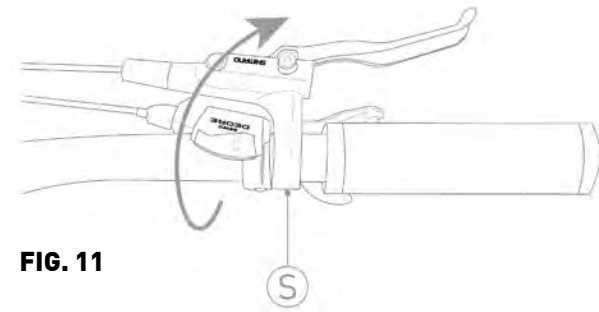

FIG. 11

6.2.6 Suspensions regulations

At this point, adjust the suspension to make it more comfortable to use the pedal assisted bicycle.

Depending on the path and the load on the vehicle, it is possible to vary the stiffness of the fork by means of a special lever placed on the left side of the fork (Ref. Q - Figure 10.1).

The blue lever positioned at the top right (Ref. P - Figure 10.1), on the other hand, allows you to block the compression, effectively transforming the suspension from amortized to rigid. Furthermore, it is possible to adjust the return speed of the suspension itself by turning the red knob positioned in the lower right part of the fork (Ref. R - Figure 10.2).

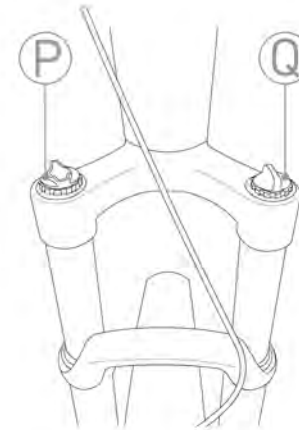

FIG. 10.1



FIG. 10.2



DANGER

RULES

It is absolutely forbidden to adjust the devices of the bicycle unless you are experienced and trained to do so. Incorrect adjustment can cause serious injuries. Therefore, if you are unable to adjust these functions, contact specialized personnel.

The manufacturer is not liable for accidents deriving from incorrect adjustment of the pedal assisted bicycle devices.

7. BICYCLE USAGE

The pedal assisted bicycle was designed and built for use in open places, with asphalt surfaces or the like, for amateur use.

- It is forbidden to load a passenger other than the driver.
- Can only be used by experienced adults and children.
- The use of pedal assisted bicycles is not recommended for pregnant women.
- Do not take alcohol or drugs before riding the pedal assisted bicycle.
- Do not ask the pedal assisted bicycle to perform better than that for which it was designed. Use the bicycle only in the manner and for the intended uses described in this manual.
- Never ride the pedal assisted bicycle with parts that have been disassembled.
- The pedal assisted bicycle cannot be used on very wet, icy or slippery surfaces.
- Avoid very uneven surfaces and obstacles.
- Drive with both hands on the handlebar.
- Replace worn and / or damaged parts. Eventually, if necessary, have it checked by authorized personnel.

Before leaving, carry out all the checks described in the previous chapter and always keep concentrated while driving, for your own safety and that of others.



DANGER

INJURY

- **Check that all the controls are perfectly functional.**
- **Always respect the highway code.**
- **Use suitable protective equipment (helmet, etc ..)**



7.1 Bicycle usage

Before using the pedal assisted bicycle in places open to traffic, it is advisable to familiarize yourself with the behavior of the vehicle.

The first uses must be made in private environments away from traffic, other cyclists or obstacles of any kind.

The driver must adapt the travel speed of the pedal assisted bicycle to the conditions of the route and the presence of other vehicles or pedestrians. Especially when tackling the curves you must keep a moderate speed (the smaller the corner radius, the lower the speed must be). When the driver stops pedaling or the speed reaches 25 km / h, the electric motor no longer provides assistance and the bicycle proceeds completely managed by the pedals.

It is essential to gain experience in riding the pedal assisted bicycle, before proceeding at high speed. If you do not want to use the engine, simply remove the battery or set the lowest level of assistance.

7.2 Braking

To minimize the stopping distances of the vehicle, it is necessary to abruptly stop pedaling and subsequently apply braking force gradually in order not to destabilize the vehicle.

Encourage the use of the rear brake when braking to stabilize the bicycle.



ATTENTION

DRIVING CONDUCT

Excessive braking force can trigger harmful phenomena such as wheel locking or vehicle overturning. It is very dangerous to brake when cornering: you could lose control of the bike.

7.3 Parking

The bicycle is not equipped with a side stand for support, therefore, before leaving the bicycle, check that the pedal-assisted bicycle is resting on stable ground and remains in a stable position.

The bicycle must be parked in the designated parking areas and, in any case, without obstructing the passageways, emergency exits, electrical panels and fire-fighting stations.



8. MAINTENANCE

8.1 General



DANGER

INJURY

During all maintenance work, follow the appropriate safety measures. All maintenance operations must be carried out with the battery disconnected from the pedal-assisted bicycle and from the battery charger and the bicycle resting in a stable

To maintain the full functionality of your pedal assisted bicycle for a long time, it is necessary to carry out maintenance as prescribed, with correctness and professional skills.

After each routine maintenance operation, a check on the perfect functioning of all the controls is mandatory.

8.2 Maintenance and daily checks

8.2.1 Labels and pittograms

Check the legibility and presence of the CE plate, and of the warning stickers affixed to the bodywork of the bicycle.

8.2.2 Wheels

Using the appropriate inflation valve on the rims, check the inflation pressure of the tires using a compressor and a gun with a pressure gauge, or a pump. Check the condition of the tread, the rim and the attachment of the rims to the hubs. In the event of a tire replacement, contact your authorized dealer or a qualified tire dealer.



Do not inflate the tires beyond the allowable value indicated by the manufacturer on the side surface of the tires.

ATTENTION-

8.2.3 Brakes

The brakes must be adjusted in such a way as to ensure effective braking and at the same time the control levers must have adequate travel, in order to modulate the braking: in other words, the brakes must not be too slow or too tight. Check that the brake discs and pads are not contaminated with oils or soaps. Check the effectiveness of the braking system on flat ground and at low speeds. Check the wear of the brake pads annually by visiting authorized personnel.

Fine adjustment of the brakes Adjustment of the brakes must only be carried out by authorized personnel.



ATTENTION

The adjustment of the brakes must be carried out only by authorised personnel.



8.3 Maintenance and weekly checks

8.3.1 Washing and cleaning

Cleaning the pedal assisted bicycle is not only a matter of decorum, but also allows you to immediately detect any defect in it.

In order not to damage or compromise the functioning of the various components, especially the electrical parts, cleaning must be carried out taking certain precautions. It is absolutely forbidden to direct jets of pressurized water towards the electrical parts, the engine and the battery, for which washing with a sponge is recommended.

Before starting the pedal assisted bicycle, dry completely with low pressure compressed air and check that there is no residual moisture on the electrical components.

8.3.2 Check and lubrication of the chain

It is important to periodically clean and lubricate the chain to avoid corrosion due to atmospheric agents.

1. Clean the entire length of the links with a rag.
2. Spray all the links with a special grease in spray for transmission chains.

Check the correct tension of the chain by positioning the gearbox in the two different extreme positions allowed by the sprocket set.



CORRECT LUBRICATION OF THE CHAIN
Be extremely careful not to get the lubricant on the bicycle's brakes or tires. This can lead to serious injuries !!

8.3.3 Chassis check

The supporting frame of the pedal assisted bicycle and the welds must be free of visible defects such as: cracks, deformations, incisions, corrosion, etc.

Make sure that all the bolts on the pedal assist bike are tight.



8.4 Maintenance and monthly checks

8.4.1 Control of circuits and electrical components

Check the condition and fastening of the battery cables: the sheaths of the electric cables must be in good condition and the terminals must be well tightened, not corroded and covered with insulating grease.

Check that all bulbs and warning lights are switched on correctly.

8.4.1 Control and adjustment of the rear derailleur

Adjusting the lower and upper limit switches of the rear derailleur: Turn the two screws (Ref. U-T - Figure 12) so that the chain does not come out. The chain displacement device must be in line with both the largest gear and the smallest one. (Ref. Figure 13)

Front limit adjustment

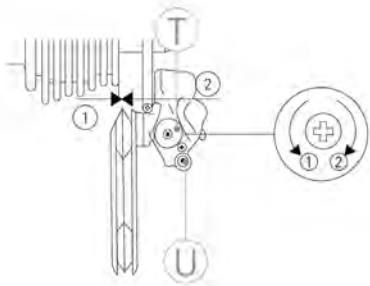

FIG. 12

Back limit adjustment

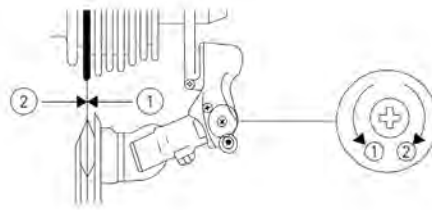

FIG. 13

Adjust the tension of the cable by acting on the appropriate control to ensure the immediate response of the rear derailleur to the control of the handle on the handlebar. (Ref. Figure 14)

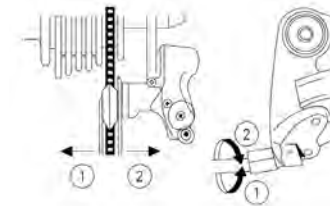

FIG. 14

To prevent damage to the gearbox, it is recommended not to exert too much pressure on the pedals while shifting gears. So avoid shifting when exerting effort or driving on slopes.

9. TECHNICAL ASSISTANCE AND SPARE PARTS

If you need technical assistance, contact your authorized dealer.
If non-original parts are fitted, the guarantee becomes invalid!



ATTENTION

ORIGINAL SPARE PARTS

The manufacturer disclaims any liability for damage of any nature, generated by the use of non-original spare parts.

10. WAREHOUSE DEPOSIT

In the event that the pedal assisted bicycle should be stored and kept for long periods of inactivity, the following operations must be carried out:

- Repair it in a dry and ventilated place.
- Carry out a general cleaning of the pedal assisted bicycle.
- Remove the battery from its seat and place it in a special storage site (fully charged and recharge regularly).
- Leave the bicycle on a suitable support.
- Protect exposed electrical contacts with antioxidant products.
- Grease all surfaces not protected by paints or anti-corrosion treatments.



11. DISPOSAL OF COMPONENTS AND MATERIALS



ATTENTION

DISPOSAL OF MATERIALS

The disposal of packaging, waste and vacuumed dust, the replaced parts, the pedal assisted bicycle as a whole at the end of its expected life, must be carried out in respect of the environment; avoiding to pollute the soil, water and air, respecting in any case the national and local legislation in force on the subject.

Indications for waste treatment:

- Ferrous materials, aluminum, copper: these are recyclable materials to be given to a specific authorized collection center.
- Plastic materials, fiberglass, gaskets, tires: these are materials to be sent to landfills or to a special recycling center.
- Batteries must be taken to authorized disposal centers.

Divide the materials according to their nature, appointing specialized companies authorized to dispose of them, in compliance with the provisions of the law.

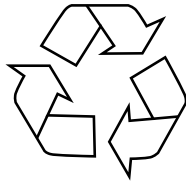

12. WARRANTY NORMS

MBM S.R.L. guarantees that its bicycles are free from any manufacturing or invoice defect. This warranty covers the repair or replacement of any part which is found to be defective, subject to the following conditions.

TERMS AND CONDITION

- **Warranty period:** the pedal assisted bicycle is guaranteed for 24 months on the mechanical and electrical parts, except for the batteries and all components subject to wear. The batteries are covered by a conditional warranty for 24 months and limited to their correct use:

- first 6 months 100% coverage;
- from the 7th to the 12th month 50% coverage;
- from the 13th to the 24th month 25% coverage;

If the battery has been allowed to discharge below the permitted limit, the manufacturer is not liable for any damage.

- In order to make this warranty effective, you must fill in the online form which can be accessed via the QR CODE or by connecting directly to the warranty.mbmbike.it website no later than 15 days from the date of purchase of the bicycle. You will need the serial number and a photograph of the proof of purchase from the authorized dealer. The serial number is printed on the plate affixed to the straight tube of the bicycle at the bottom bracket.

- Claims must be made through an official dealer by presenting the original fiscal document (receipt or invoice) and printing the confirmation of the activation of the guarantee that you will receive via e-mail after filling out the online form.

- The warranty provides for the free replacement of any defective or prematurely worn part as long as all the requirements have been respected and there is no improper use of the bicycle. The manufacturer's obligations are limited to the replacement of defective parts.

- Ultimately, our Technical Department will decide whether or not the defective part or bicycle falls within the conditions of this warranty.

- This warranty does not cover in any way the replacement of parts worn out by normal use of the bicycle.

- This warranty does not apply in any case to breakdowns or damage caused by improper use of the bicycle, use of the bicycle for sports competitions, by the application of non-original accessories, or by improper maintenance interventions.



FIG. 15



**ACTIVATE YOUR
WARRANTY HERE**



ESCLUSIONS

Normal wear and tear on parts subject to it, such as tires, chains, brakes, cables and sprockets in situations where there are no units or material defects.

- Bicycles serviced by an unauthorized MBM distributor.
- Changes from the original packaging.
- Use of the bike for abnormal activities, such as competition and / or commercial activities, or for purposes other than those for which the bike was designed.
- Damage caused by not following the user manual.
- Damage to paints and decals as a result of having exposed the bike or having used it in harsh conditions and climates.
- Labor costs for the replacement of parts.
- Transportation fee.

Except as provided in this warranty and remaining subject to all other warranties, MBM and its employees and agents will not be liable for loss or damage of any kind (including incidental and consequential losses or damage caused by negligence or failure) originating from or relating to any MBM bicycle.

M.B.M. S.r.l. does not assume responsibility for damage to property and people, due to improper use of the vehicle.

13. CONFORMITY

Hybrid-drive bicycles with a maximum support speed of 25km / h fulfill the requirements:

- 2006/42 / EC Machinery Directive
- 2014/30 / UE Electromagnetic Compatibility Directive
- 2011/65 / EU Rohs Directive

These bicycles also comply with the following non-harmonized standards:

- Electric bicycles: EN 15194

Disclaimer:

We strongly recommend that you do not remove or replace any original equipment or modify the bicycle in any way that could change its design and / or function. Such modifications could seriously damage the handling, stability and other aspects of the bicycle, making it unsafe. The removal or modification of parts, or the use of non-original equipment as spare parts, can make the bike no longer compliant with applicable standards and laws. To ensure safety, quality and reliability, use only MBM original parts or authorized spare parts for repair and replacement.





M.B.M. S.r.l. Unipersonale

Via Emilia Levante, 1671/73/75 | 47521 Cesena (FC)

Tel.: + 39 0547 -300364

Fax: +39 0547-304326

Email: info@mbmbike.it



W W W . M B M B I K E . I T