FUNK URBAN



FUNK URBAN 20"



USER MANUAL

INDEX

1. FOREWORD	4
1.1 General	4
1.2 Assistance	4
1.3 Graphic form of security warnings	4
2. SECURITY WARNINGS	5
2.1 General safety rules	5
2.2 Responsibilities	5
2.3 Warning for users	6
2.4 Maintenance warnings	6
2.5 Other provisions	7
2.6 Unpacking and tuning	7
2.6.1 Saddle adjustment	7
2.6.2 Handlebar adjustment	8
2.6.3 Pedal mounting	9
3. BICYCLE DESCRIPTION	10
3.1 General description	10
3.2 Data sheet	11
3.3 Brake levers	12
3.4 Speed change	12
3.5 Assistance system management	13
3.5.1 Commands	13
3.5.2 Turning the system on/off	13
3.5.3 Assistance activation	14
3.5.4 Support levels	14
3.5.5 Single distance reset	15
3.5.6 Walking assistance mode	15
3.5.7 Turning the lights on/off	15
3.5.8 Battery indicators	16
3.5.9 Error codes	16
3.5.10 Problem solving	17
3.6 Battery	18
3.6.1 Battery charge status	18
3.6.2 Battery removal/installation	18
3.6.3 Battery charging	20
3.6.4 Problem solving	20
3.7 Front and rear light	21
3.8 Front suspension	21

4. CONDITION OF USE AND INTENDED ENVIRONMENT	22
4.1 Intended use	22
4.2 Environment of use	22
4.3 Improper uses and contraindications	23
5. LIFTING AND TRANSPORT	24
5.1 Lifting	24
5.2 Transport	24
6. COMMISSIONING	25
6.1 Battery charge	25
6.2 Preliminary functional settings	26
6.2.1 Control devices	26
6.2.2 Wheels	26
6.2.3 Braking	26
6.2.4 Frame, handlebar and seat position	27
6.2.5 Brake adjustment	28
6.2.6 Suspension adjustment	28
6.2.7 Headlight operation	29
7. USE OF THE BICYCLE	29
7.1 Driving the bicycle	30
7.2 Braking	30
7.3 Bicycle parking	30
8. MAINTENANCE	31
8.1 General	31
8.2 Daily maintenance and checks	31
8.2.1 Tags and pictograms check	31
8.2.2 Wheel check	31
8.2.3 Brake functional sitting	32
8.3 Weekly maintenance and checks	32
8.3.1 Washing and cleaning	32
8.3.2 Lubrication and chain tension control	32
8.3.3 Frame and bolt control	32
8.4 Monthly maintenance and checks	33
8.4.1 Control of electrical circuits and components	33
8.4.2 Rear derailleur control and adjustment	33



9. TECHNICAL ASSISTANCE AND SPARE PARTS	34
10. WAREHOUSE	34
11. DISPOSAL OF COMPONENTS AND MATERIALS	35
12. WARRANTY RULES	36
13. CONFORMITY	37



1.FOREWORD

1.1 Generalities

This manual is an integral and essential part of the FUNK URBAN 20" pedal-assisted bicycle. Before commissioning, it is essential that users read, understand and scrupulously follow the following provisions. The manufacturer is not liable for damage caused to persons and / or things or to the pedal-assisted bicycle if it is used incorrectly with respect to the requirements Indicated.

With a view to continuous technological development, the manufacturer reserves the right to modify the components, including the frame, without notice and without this manual being automatically updated.

1.2 Assistance

For any inconvenience or request for clarification contact the authorized dealer, who has competent and specialized personnel, as well as specific equipment and original spare parts.

1.3 Graphic form of security warnings

To identify security messages, the following graphical signal symbols will be used in this manual. They have the function of attracting the attention of the reader / user for the correct and safe use of the assisted bicycle.



ATTENTION

Highlights behavioral rules to be kept in order to avoid damage to the pedal-assisted bicycle and / or the onset of dangerous situations.



DANGER

Highlights the presence of hazards that cause residual risks to which the user must pay attention in order to avoid accidents or material damage.

2. SECURITY WARNINGS



ATTENTION

USE OF THE PEDAL-ASSISTED BICYCLE

Each user must first have read the instruction manual, in particular the chapter on safety claims.



ATTENTION

RISK ASSOCIATED WITH THE USE OF THE PEDAL-ASSISTED BICYCLE

- Notwithstanding the application of safety devices, for the safe use of the pedal-assisted bicycle , all the requirements relating to the prevention of accidents reported in this manual.
- Always stay focused while driving and **DO NOT** underestimate the residual risks associated with the use of the assisted bicycle.

2.1 General safety rules

Even if you are already practical in the use of pedal-assisted bicycles , you must follow the instructions given here, in addition to the general precautions to be observed during the driving a motor vehicle . In particular:

- Acquire full knowledge of the pedal-assisted bicycle;
- Read the manual carefully to know the operation, the safety devices and all the precautions necessary for the safe use of the vehicle. All this to allow safe use;
- Carefully maintain the pedal-assisted bicycle in perfect condition;

For any inconvenience or request for clarification contact without hesitation the authorized dealer, who has competent and specialized personnel, specific equipment and original spare parts.

2.2 Responsibilities

Failure to comply with the operating instructions and safety requirements contained in this manual exempts the manufacturer from any liability.

If the maintenance of the pedal-assisted bicycle is carried out in a manner that does not comply with the instructions provided, with non-original spare parts or in any case in such a way as to compromise its integrity and modify its characteristics, the manufacturer shall will be relieved of any responsibility inherent in the safety of persons and the defective operation of the pedal-assisted bicycle.



**ATTENTION****UNAUTHORIZED CHANGES**

If you hear unusual noises or feel something strange, stop the pedal-assisted bicycle immediately. Carry out a check afterwards and, if necessary, contact the authorized dealer.

For any data not included or not deductible from this manual, it is recommended to consult the authorized dealer directly.

2.3 Warnings for users

1. It can only be used by experienced adults and children;
2. Do not take alcohol or drugs before riding the pedal-assisted bicycle;
3. These models of pedal-assisted bicycles are designed and built to be used outdoors, on roads and private and public environments;
4. Do not ask the pedal-assisted bicycle for performance higher than that for which it was designed;
5. Never ride the pedal-assisted bicycle with disassembled parts;
6. Avoid uneven surfaces and obstacles;
7. Ride with both hands on the handlebars;
8. Replace worn and/or damaged parts and check that the guards are working properly before use.

2.4 Maintenance warnings

1. Any maintenance must take place with the battery disconnected;
2. During each maintenance phase, operators must be equipped with the necessary accident prevention equipment;
3. The tools used for maintenance must be suitable and of good quality;
4. Do not use gasoline or flammable solvents as detergents, but always resort to non-flammable and non-toxic solvents;
5. Limit as much as possible the use of compressed air for cleaning (max 2 bar) and protect yourself with glasses with side guards;
6. Never resort to the use of open flames as a means of illumination when carrying out verification or maintenance operations;
7. After any maintenance or adjustment, make sure that no tools or foreign bodies remain between the moving parts of the pedal-assisted bicycle.

**ATTENTION****ORIGINAL SPARE PARTS**

Use only original spare parts supplied by M.B.M. S.r.l. Unipersonal. Any liability of the Manufacturer for damage or loss of functionality caused as a result of the use of non-original accessories and parts is excluded.



2.5 Other provisions

The first thing to do when starting use is to check the presence and integrity of the protections and the operation of the safety devices. If you find any defects, do not use the pedal-assisted bicycle!



DANGER

GUARDS

It is strictly forbidden, therefore, to modify or remove the guards, controls, labels and indication plates.

2.6 Unpacking and tuning

The pedal-assisted bicycle is delivered fully assembled and working.

2.6.1 Saddle adjustment

The adjustment of the height of the saddle is an essential prerogative for the correct use of the pedal-assisted bicycle. Incorrect adjustment can generate structural breaks to the frame.

Adjust the height of the saddle by operating the quick release mechanism (Ref. A – Figure 1). Check that the mechanism is tightened before testing the seat and using the medium. Do not lift the saddle beyond the limit sign placed in the tube (Ref. B – Figure 1)

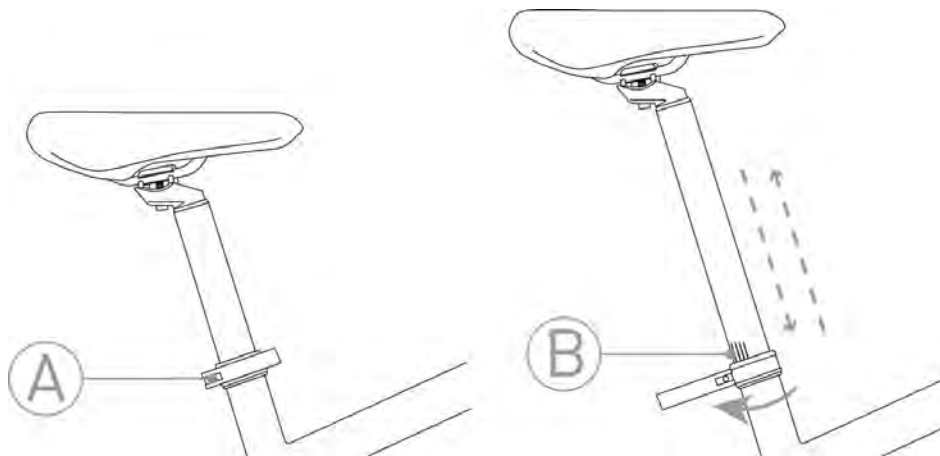

FIG. 1



DANGER

IMPORTANT NOTICE:

For your safety, the reference mark of the seatpost tube (B) should never be outside the tube where the seatpost tube is inserted.



ATTENTION

ASSEMBLY

In the event that you do not have the appropriate instrumentation for adjustment or do not have the capabilities, contact the authorized dealer.



2.6.2 Handlebar adjustment

For a comfortable posture on the bike, which does not cause neck or back pain, we recommend the handlebar column height adjustment.

Adjust the height of the handlebar column by operating the quick release mechanism (Ref. C – Figure 2). Check that the mechanism is tight before using the vehicle. Do not lift the handlebar column beyond the height allowed by the mechanism. To facilitate the transport and storage of the pedal-assisted bicycle, it is possible to unhook and flex the steering column by means of the centrally placed hinge (Ref. D – Figure 2).

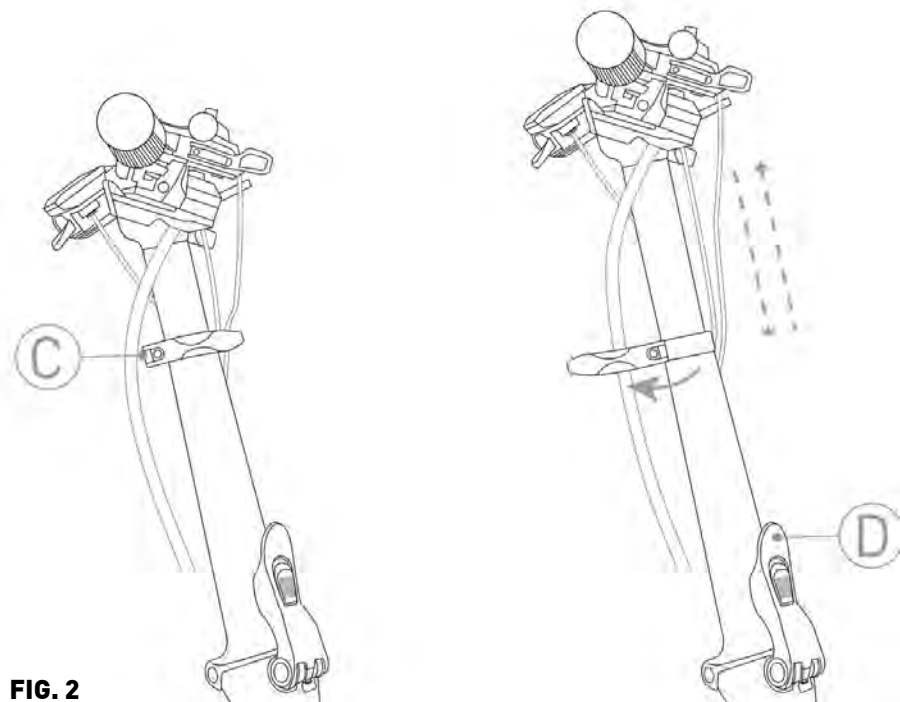

FIG. 2



ATTENTION

Do not lift the handlebar column beyond the maximum height allowed by the mechanism.



ATTENTION

ASSEMBLY

In the event that you do not have the appropriate equipment for adjustment or do not have the capabilities contact the authorized dealer .

Use the hinge of the handlebar column by lifting the safety mechanism (Ref. E – Figure 3) and open the hinge. Check that the release mechanisms are tightened before using The vehicle.



ATTENTION

Do not use the pedal-assisted bicycle with the zipper unhooked .

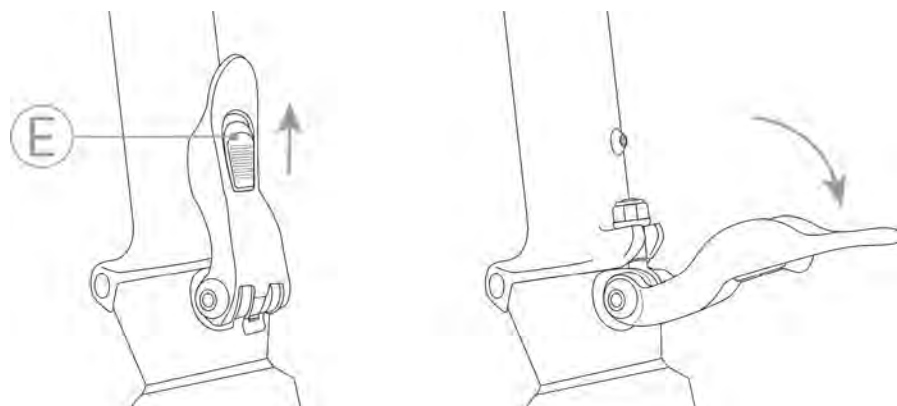

FIG. 3



2.6.3 Pedal mounting

Right pedal: IT is identified by the letter "R" marked on its pin. For pedal mounting, screw by turning the pin clockwise. (Figure 4).

Left pedal: it is identified by the letter "L" marked on its pin. For pedal mounting, screw by turning the pin counterclockwise (Figure 4).



ATTENTION

ASSEMBLY

For a correct tightening of the pedals, it is necessary to use a key of 15



ATTENTION

ASSEMBLY

In the event that you do not have the appropriate equipment for adjustment or do not have the capabilities, contact the authorized dealer.

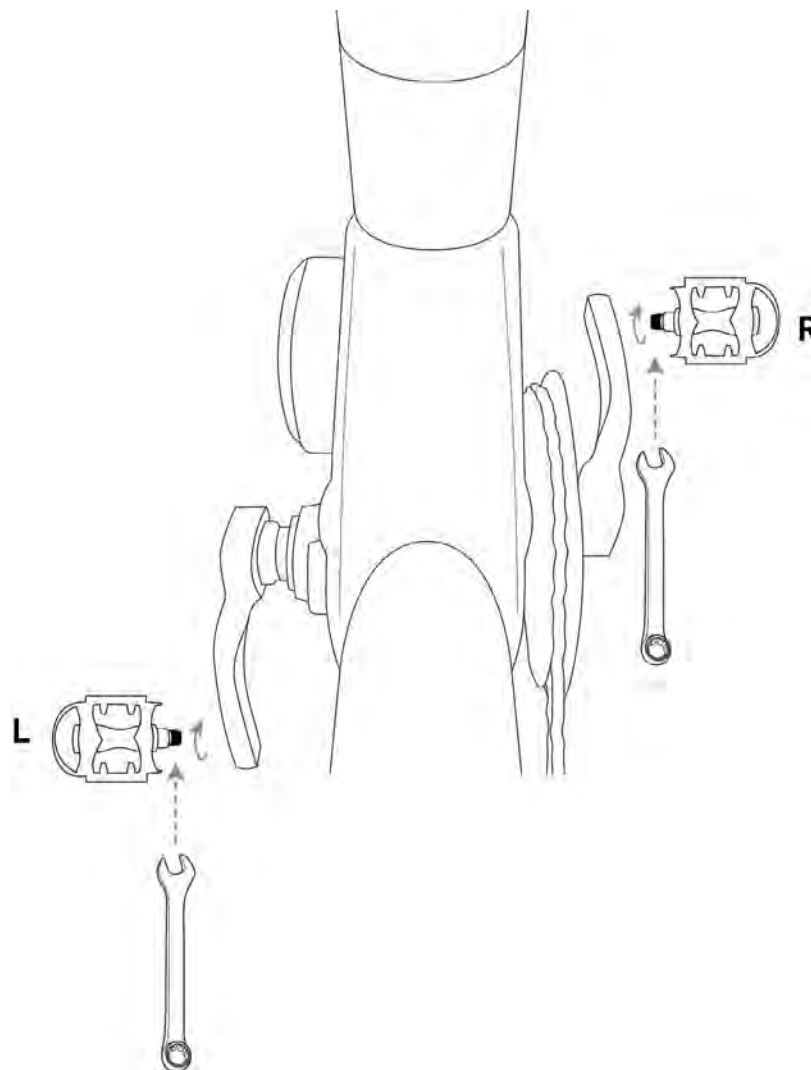

FIG. 4

3. BICYCLE DESCRIPTION

3.1 General description

The pedal-assisted bicycle is designed and built to be used outdoors, on roads and private or public environments. In particular, the components and the type of pedal-assisted bicycle allow you to tackle routes with asphalt surfaces or with similar characteristics without particular roughness.



DANGER

INCORRECT AND UNINTENDED USE

The bicycle has been designed and manufactured for the specified use; a different use and failure to comply with the technical parameters set by the manufacturer may constitute a dangerous condition for users.

The pedal-assisted bicycle is equipped with a rechargeable battery and an electric motor, whose intervention takes place only in conjunction with the pedaling and gradually stops as the speed of the vehicle approaches 25 km / h, and then stops completely at that speed.

For the management of the assistance system there is a special display located on the left side of the handlebar. On the right side of the handlebar there is a control system for adjusting the gears.



3.2 Scheda tecnica

1. HANDLEBAR AND CONTROLS
2. ENGINE
3. SADDLE
4. BATTERY
5. PEDAL
6. FORK
7. FRONT LIGHT
8. REAR LIGHT
9. REAR DERAILLEUR

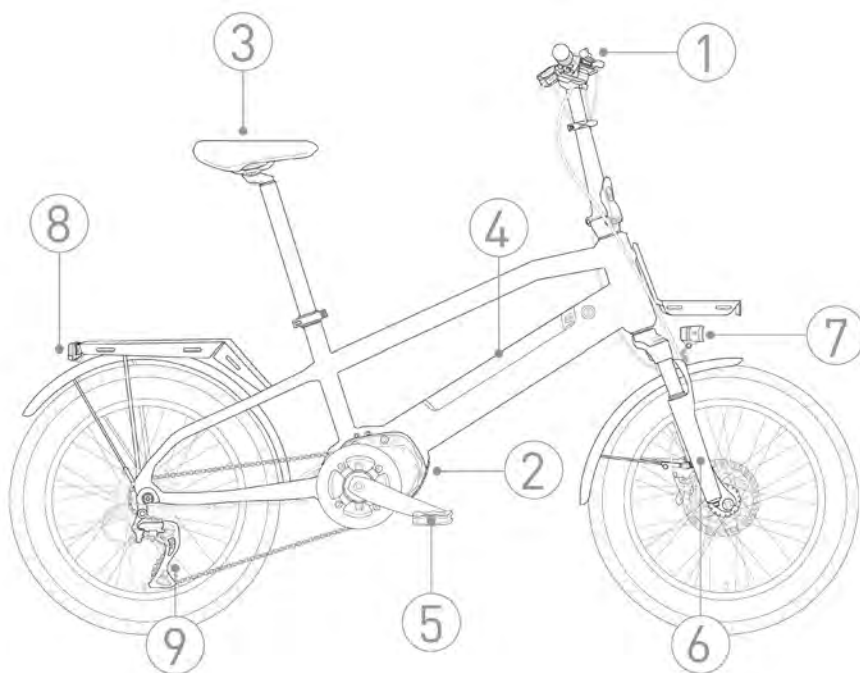

CODE	E500 / E500CR
FRAME	HYDROFORMED ALUMINIUM
FORK	SUSPENSION WITH ADJUSTMENT
CRANKSET	38 TEETH
REAR DERAILLEUR	ACERA
SHIFTERS	8 SPEEDS
BRAKES	SHIMANO MT 200 HYDRAULIC
DISKS	SHIMANO RT26 ANT: Ø160MM POST:Ø160MM
WHEELS	20*3,0
SADDLE	MBM FUNK
PEDAL	RIGHT AND LEFT IN NON-SLIP POLYMER MATERIAL
LIGHTS	SPANNINGA 40 LUX
ENGINE	CENTRAL MOTOR OLI MOVE ONE 60 NM
BATTERY	SEMI-INTEGRATED SPARD YT 30240, 36V, 7AH 252 WH
MAX SERVICE SPEED	25 KM/H
DISPLAY	LCD
POWER LEVELS	5
WEIGHT	26 KG



3.3 Brake levers

The brake levers (Ref. F – Figure 5) are placed on the handlebars of the pedal-assisted bicycle, near the knobs (Ref. G – Figure 5). These systems make it possible to control the calipers of the disc brakes located near the wheel hubs. The right lever controls the rear brake, the left one the front brake; the braking action is proportional to the force applied on the lever.

3.4 Speed change

The pedal-assisted bicycle has an 8-speed gearbox with the sprockets positioned on the rear wheel hub and selectable by means of the opposing levers located at the base of the right knob. The indicator (Ref. H – Figure 5) presents at the bottom of the handlebar allows you to view the selected ratio.

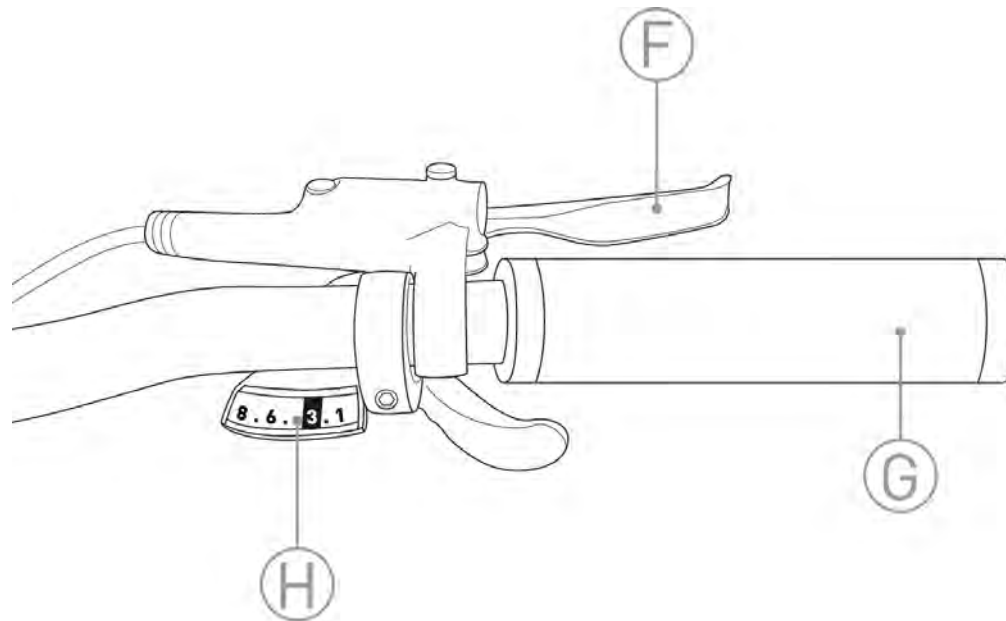

FIG. 5

3.5 Assistance system management

3.5.1 Commands

To manage the assistance system there is a display on the left side of the handlebar. This device allows you to vary the level of assistance and to view information regarding the path and status of the battery (Figure 6).

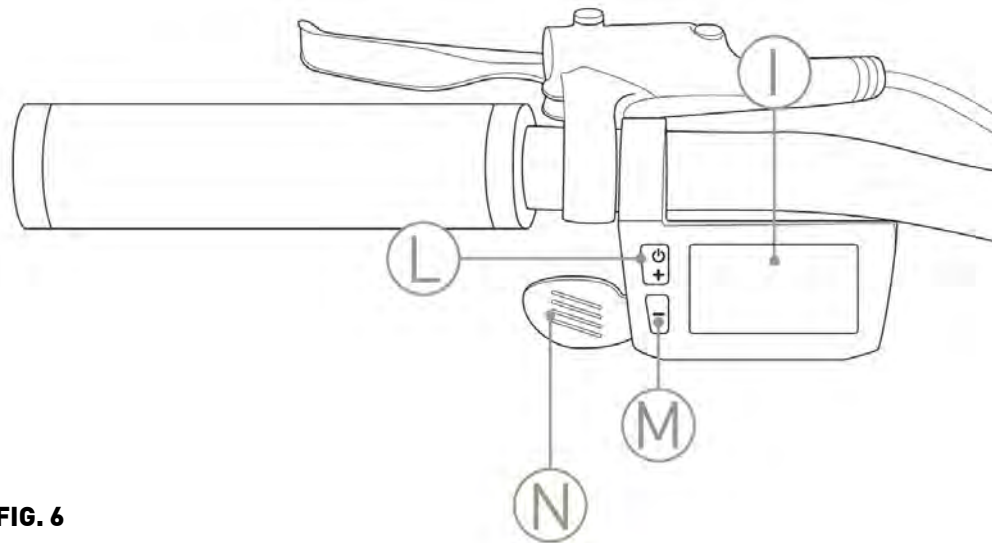

FIG. 6

I - Display;

L - On /off button and increase the level of assistance;

M - Mode button and reduction of the level of assistance;

N - Lever walking assistance mode.

3.5.2 Turning the system on/off

To activate the system you must first turn on the battery; after that, press and hold the on/off button. (Ref. L - Figure 6). To turn off the system, press and hold the on/off button (Ref. L - Figure 6).

3.5.3 Activate support

The engine is activated and deactivated immediately if the pedaling stops. The power of the motor depends on the force imposed on the pedals according to a multiplicative factor depending on the level of assistance selected.

Press and release the power button (Ref. L - Figure 6) to increase the level of assistance. To decrease the level of assistance press and release the “-” button (Ref. M - Figure 6). The level of assistance can be selected from any screen of the display.

The power of the engine depends on the force imprinted on the pedals according to a multiplicative factor based on the selected level of assistance. The assistance drops linearly until it reaches 25 km/h. Once this speed has been exceeded, there is automatic deactivation of the assistance.

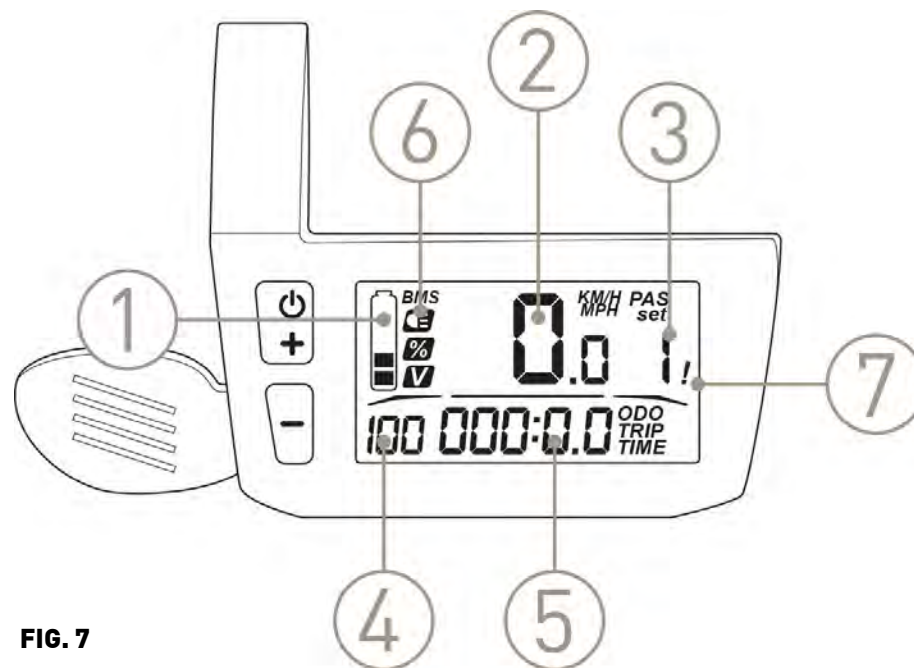

FIG. 7

- 1 - Battery charge indicator
- 2 - Speed
- 3 - Level of assistance
- 4 - Percentage of battery charge
- 5- Total Distance Traveled (ODO)/Single Distance (TRIP). The two values are automatically toggled on the display.
- 6- Lights
- 7- Error (see section 3.5.9 for error codes).

3.5.4 Assistance level

LEVEL 0 - NOTHING ASSISTANCE

LEVEL 1 - ASSISTANCE 12,5%

Recommended route : plain - long distances

LEVEL 2 - ASSISTANCE 25%

Recommended route : plain/hilly - medium-long distances

LEVEL 3 - ASSISTANCE 50%

Recommended route : hilly /medium climb - medium distances

LEVEL 4 - ASSISTANCE 75%

Recommended route : ascent - medium short distances

LEVEL 5 - ASSISTANCE 100%

Recommended route : challenging climb - short distance



3.5.5 Single distance reset

With the device turned on, press the power button and the “-” button (Ref. L,M - Figure 7.1) at the same time to reset the single distance (TRIP).

3.5.6 Walking assistance mode

The pedal-assisted bicycle is equipped with the function of walking assistance. This function allows you to move the bike more easily during manual movement in case you face small climbs.

In flat routes it is useful for starting the ride, up to a speed of 6 km / h.

To activate the above mode, turn on the assistance system using the appropriate button (Ref. L - Figure 7.1).

At this point, set the assistance level to 0 and press the lever (Ref. N - Figure 7.1) to activate the walking assistance mode. Once the lever is released, the assistance mode automatically turns off

3.5.7 Turning the lights on/off

With the device turned on, press and hold the “-” button (Ref. M - Fig. 7.1) for 3 seconds to turn on the lights of the pedal-assisted bicycle; to turn off the lights press and hold the “-” button (Ref. M - Fig. 7.1) for 3 seconds.

The status of switching on and off of the lights of the pedal-assisted bicycle is indicated by the relative icon on the display (Ref.6 - Fig. 7.1).

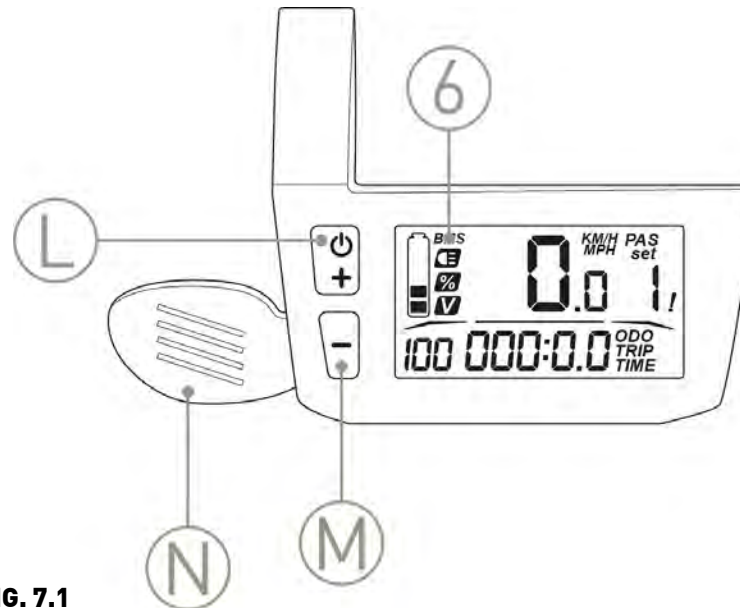

FIG. 7.1



3.5.8 Battery indicators

The state of charge of the battery (Ref.1 - Fig. 7) is indicated on the left side of the display.

When the battery is fully charged, 5 bars appear on the display; the bars gradually decrease as the battery discharges.

When the battery charge is low the last bar flashes to warn that the battery needs to be recharged.

3.5.9 Error codes

In the event of a malfunction, the display automatically shows a 4-character code corresponding to the fault encountered. Error codes are displayed on the right side of the display and highlighted by an exclamation mark. To remove the code to turn the device off and on again.



ATTENTION

Depending on the type of failure, the system may prevent the engine from starting or running at maximum power.

ERROR CODE	DESCRIPTION
0001	PROBLEM COMMUNICATING WITH BATTERY. BATTERY STATUS DATA MAY BE DISPLAYED INACCURATELY. CHECK THAT THE WIRING AND CONTACTS OF THE BATTERY ARE CONNECTED CORRECTLY AND INTACT.
0101	COMMUNICATION PROBLEMS BETWEEN THE TRANSMISSION UNIT AND THE GRAPHICAL INTERFACE.
	CHECK THAT THE WIRING IS INTACT AND CONNECTED CORRECTLY.
0104	SPEED SENSOR NOT DETECTED.
	CHECK THAT THE SPEED SENSOR AND MAGNET ARE CORRECTLY ALIGNED.
0105	CHECK THAT THE SENSOR IS INSTALLED AND CONNECTED CORRECTLY.
	PROBLEMS WITH THE TORQUE SENSOR SIGNAL. THE TORQUE SENSOR SIGNAL IS FAULTY. THE ENGINE WILL RUN AT REDUCED POWER.



0106	INADEQUATE RESPONSE OF THE TORQUE SENSOR. THE TORQUE SENSOR IS FAULTY.
0801	FAILURE OF THE MOTOR ROTATION SENSOR.
0802	FAILURE OF THE PEDAL ROTATION SENSOR.
0804	CONTROL UNIT TEMPERATURE TOO HIGH. THE TEMPERATURE SENSOR OF THE CONTROL UNIT DETECTED A TEMPERATURE HIGHER THAN THE PERMISSIBLE LIMIT.
0805	ENGINE TEMPERATURE TOO HIGH. THE ENGINE HAS REACHED A TEMPERATURE HIGHER THAN THE PERMISSIBLE LIMIT.
0806	PERIPHERAL CONNECTOR VOLTAGE ISSUES.
0808	ROTOR LOCKED. THE ENGINE DID NOT START DUE TO A MECHANICAL BLOCKAGE OR A PROBLEM WITH THE TRANSMISSION UNIT CABLE.
0809	THE BATTERY VOLTAGE IS HIGHER THAN THE MAXIMUM ALLOWED.
0810	PROBLEMS WITH THE ELECTRIC CURRENT SENSOR.
0811	THE CONTROL UNIT HAS DETECTED AN EXCESS OF ELECTRIC CURRENT.
1101	COMMUNICATION PROBLEMS BETWEEN THE USER INTERFACE AND THE CONTROL UNIT. CHECK THAT THE CABLE IS INTACT AND CONNECTED CORRECTLY.
1102	ONE OF THE BUTTON PANEL KEYS GOT STUCK IN THE PRESSURE POSITION.

3.5.10 Problem solving

PROBLEM	CAUSE/SOLUTION
The display does not turn on	Check the connection and central system
How to handle error codes	Verify the problem based on the error code description provided in this manual.



ATTENTION-

If the problem persists after these operations, request support from a service center.



3.6 Battery

The assistance system of the pedal-assisted bicycle, to work, needs the presence of the power battery.

Specifically, the battery is removable, so you can take it out for maintenance actions or when you want to store the vehicle.

3.6.1 Battery charge status

You can view the battery charge status directly on the assistance system management display.

In the event that the battery is disassembled from the vehicle or you want to see the state of charge without turning on the assistance system, in the upper part of the battery there is a button (Ref. O – Figure 8) that allows, through a LED light of different colors (Ref. P – Figure 8), to display the charge status.

CHARGING STATUS LED:

RED LIGHT 0 – 25%

GREEN LIGHT 25 – 75%

BLUE LIGHT 75 – 100%

3.6.2 Battery removal/installation

For remove the battery secure who is the system of assistance who the battery Are Off e proceed What Follows:

1. Insert the battery lock/unlock key into the battery lock at the top right of the frame near the handlebar and turn the keys clockwise. (Ref. Q – Figure 9)
2. Holding the key rotated, unhook the battery and lift it (Ref. 2 – Figure 9)
1. Take out the battery completely, taking care not to hit the frame.

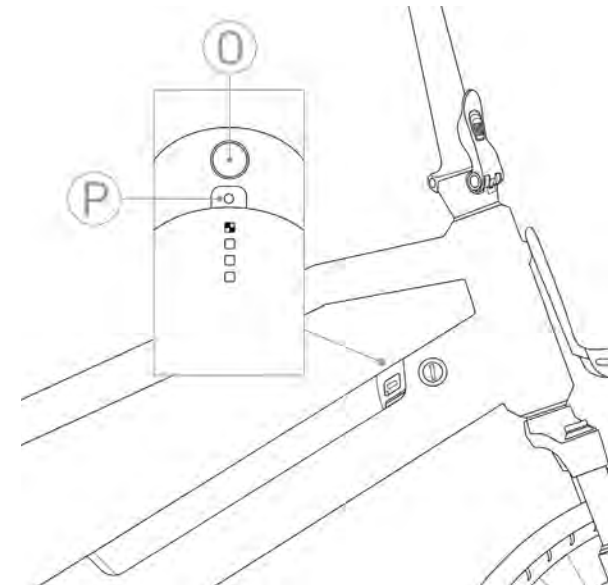

FIG. 8

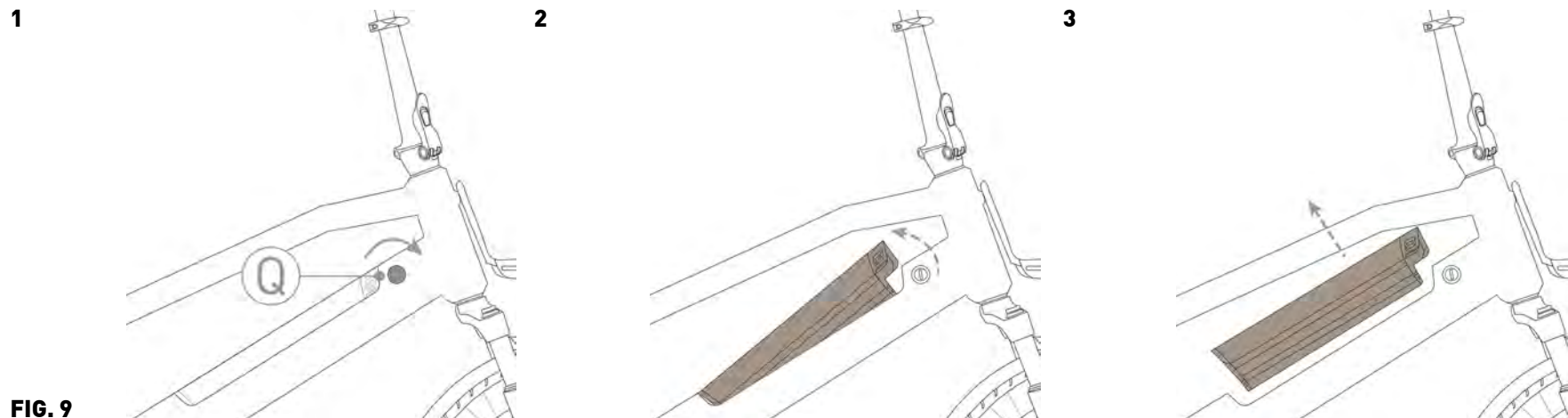

FIG. 9

For install the battery proceed What Follows:

1. This procedure must be performed without the unlock key ; remove the key if inserted;
2. Align the battery above the oblique pipe of the frame by matching the electrical connector (Ref. R – Figure 10);
1. Carefully insert the battery into the frame until you hear the closing click of the lock. At this point the battery is already self-locked.

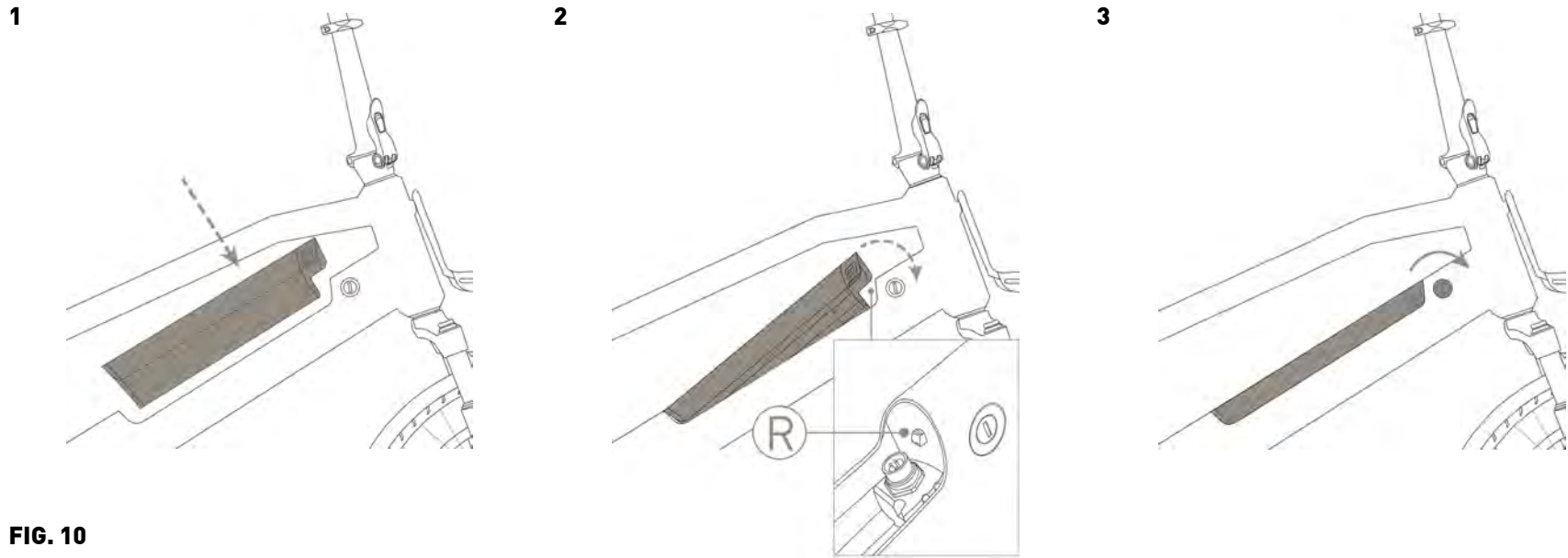

FIG. 10

3.6.3 Battery charging

The charging of the pedal-assisted battery can be carried out both with the battery fixed to the frame and with the same extracted and stored in a sheltered environment.

To charge the battery, do the following:

1. Turn off the battery and turn off the assistance system of the pedal-assisted bicycle using the appropriate button on the display. (Ref. L – Figure 6);
2. Remove the battery in case you want to charge it separately;
3. Lift the rubber stopper at the top right of the battery (Figure 11)
4. Connect the supplied battery charger with the appropriate plug;
5. Connect the battery charger to a power outlet (230 V / 50 Hz) and charge for as long as necessary.

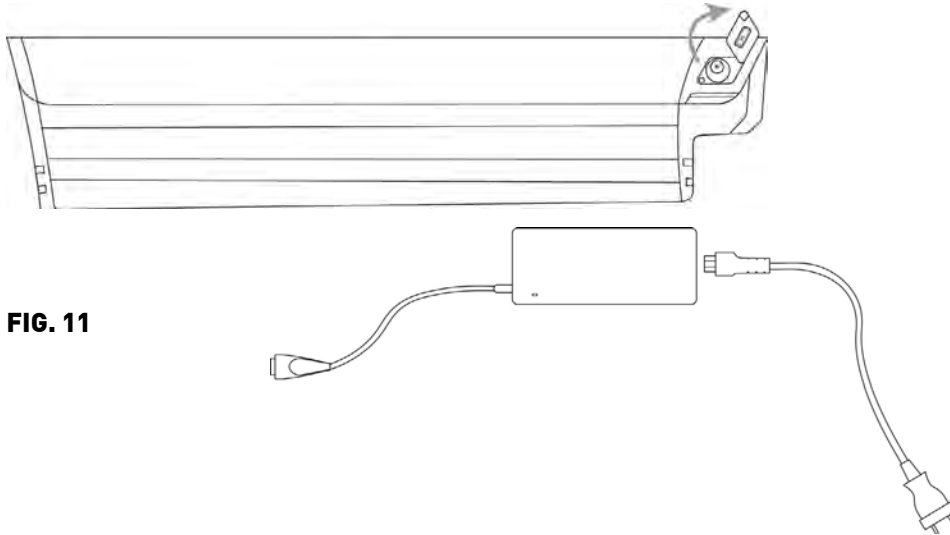

FIG. 11



ATTENTION

BATTERY CHARGER

Always connect the plug to the battery first and then the battery charger to the power outlet.

3.6.4 Problem solving

PROBLEM	CAUSE/SOLUTION
The system does not turn on	Check that the battery is charged.
PROBLEM	CAUSE/SOLUTION
Support does not activate	Check that the battery charge level is sufficient.



ATTENTION

TROUBLESHOOTING

In case the assistance system does not activate even if the battery is charged, contact your authorized dealer.



3.7 Front and rear light

To ensure visibility during both day and night hours, two lights are installed in the FUNK URBAN model, one front (Figure 12) and one rear (Figure 13). For switching on and off the lights, refer to section 3.5.7.

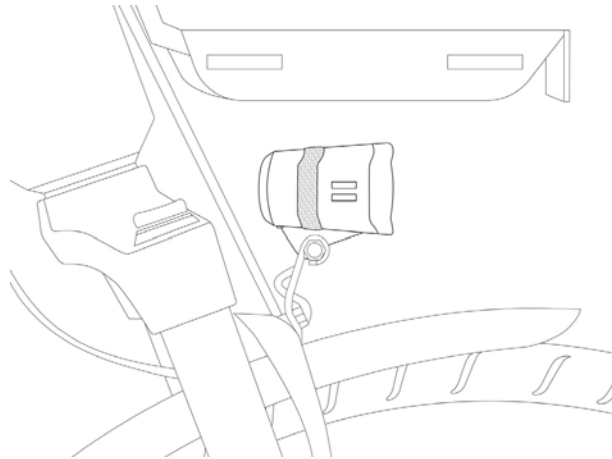

FIG. 12

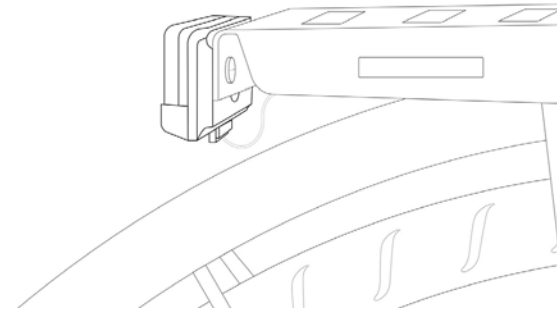

FIG. 13

3.8 Front suspension

The pedal-assisted bicycle is equipped with a system of front suspensions that allow you to dampen the solicitations caused by the roughness of the route.

The suspension model is adjustable by means of a special control placed at the top of the fork.

In particular, it is possible to vary the preload of the fork by rotating the manettino placed in the upper right part (Ref. S – Figure 14) according to the characteristics of the user and the terrain.

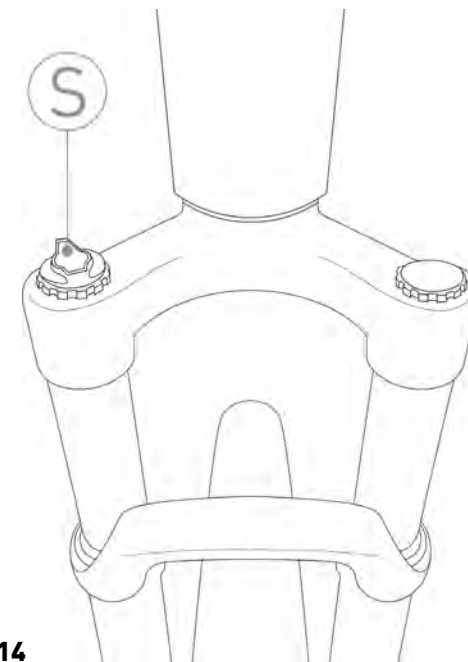

FIG. 14

4. CONDITION OF USE AND INTENDED ENVIRONMENT

4.1 Intended use

The pedal-assisted bicycle is designed and built to be used outdoors, on roads and private or public environments. In particular, the components and the type of pedal-assisted bicycle allow you to tackle routes with asphalt surfaces or with similar characteristics without particular roughness.

Any change in the state of construction can compromise the behaviour, safety and stability of the assisted bicycle and can lead to an accident.

Other types of use, or the extension of the use beyond that envisaged, do not correspond to the intended purpose assigned by the manufacturer, and therefore the same can not assume any responsibility for any resulting damage.

4.2 Environment of use

The pedal-assisted bicycle can be used outdoors, in the absence of adverse weather conditions (heavy rain, hail, snow, strong wind, etc.):

- Maximum permissible temperature: +40 °C;
- Minimum permissible temperature: 0 °C;
- Maximum permissible humidity: 70%;
- Charging temperature: 0 – 40 °C;

The environment of use may have an asphalted bottom or with not excessively high roughness.

In addition, the place of use must be illuminated, by the sun or by artificial lights, in such a way as to guarantee the correct vision of the route and the controls of the pedal-assisted bicycle (recommended from 300 to 500 lux). The pedal-assisted bicycle is equipped with a white front light and a red light rear light.



ATTENTION

PROHIBITED USE ENVIRONMENTS

The pedal-assisted bicycle must not be used:

- **In areas subject to risk of fire or explosion;**
- **In environments with corrosive and/or chemically active atmosphere;**
- **In dimly lit environments;**
- **On excessively inaccessible terrain, given the characteristics of the same (frame, wheels, etc.);**
- **In enclosed spaces, if they do not allow safe use;**
- **In extremely dark environments.**



4.3 Improper uses and contraindications

The actions described below, which obviously cannot cover the entire range of potential possibilities of "misuse" of the pedal-assisted bicycle, are to be considered absolutely Prohibited.



ATTENTION

PROHIBITED OPERATIONS

- **The execution of prohibited operations invalidates the warranty;**
- **The manufacturer declines all responsibility for any damage to property and persons resulting from the execution of prohibited operations.**



DANGER

ABSOLUTELY FORBIDDEN

- **Use the pedal assist bicycle for uses other than those for which it was built, i.e., the pleasure of a passenger;**
- **Ride the pedal-assisted bicycle in areas where there is a danger of explosions;**
- **Ride the pedal-assisted bicycle in adverse weather conditions (heavy rain, hail, snow, strong wind, etc.)**
- **Ride the pedal-assisted bicycle under the influence of alcohol or drugs;**
- **Ride the pedal-assisted bicycle if your weight is higher than allowed;**
- **Charge the battery in an environment that is too hot or not sufficiently ventilated;**
- **Cover the battery while charging;**
- **Smoke or use open flame near the charging area;**
- **Transit or stop on sloping surfaces (greater than 10%) or excessively uneven (with holes, depressions, obstacles, etc.)**
- **Perform any maintenance with the battery connected;**
- **Use non-original spare parts;**
- **Insert the limbs or fingers between the moving parts of the bicycle;**
- **Use the pedal-assisted bicycle on unpaved terrain or with similar characteristics;**



5. LIFTING AND TRANSPORT

5.1 Lifting

The weight of the PEDAL-assisted bicycle model FUNK URBAN is such that it can be lifted and transported by a person, also because of its overall dimensions.

The optimal solution to perform the movement is to grab a handlebar knob and the back of the saddle.



DANGER

CRUSHING AND IMPACT

- **During lifting, extreme caution should be exercised to avoid damage to people and property .**
- **This operation must be performed by robust people.**

The manufacturer is not liable for breakages due to lifting and/or transporting the pedal-assisted bicycle after delivery.

5.2 Transport

To ensure the safety of transport on vans it is necessary to prevent the movement of the pedal-assisted bicycle. This is achieved by binding it with bands or anchor cables in good condition. In this respect, the coupling devices must be installed so as not to damage the frame and other parts of the bicycle.



DANGER

RISK OF ACCIDENT

ALWAYS make sure that the adjustment screws of the frame and handlebars are tightly tightened before each use of the bike. Otherwise, accidents, even serious ones, could result!



6. COMMISSIONING

6.1 Battery charge

Before using the bike for the first time, you must charge the battery for at least 8 hours using the supplied battery charger. The pedal-assisted bicycle, model FUNK URBAN, is equipped with an electric motor powered by a 36V lithium-ion battery. The battery pack is positioned inside the frame in the oblique pipe of the vehicle. The average charging time varies from 4 to 6 hours. The charging operation can be carried out in a well-ventilated box and with the battery installed on the bicycle. To charge the battery proceed as in section 3.6.3

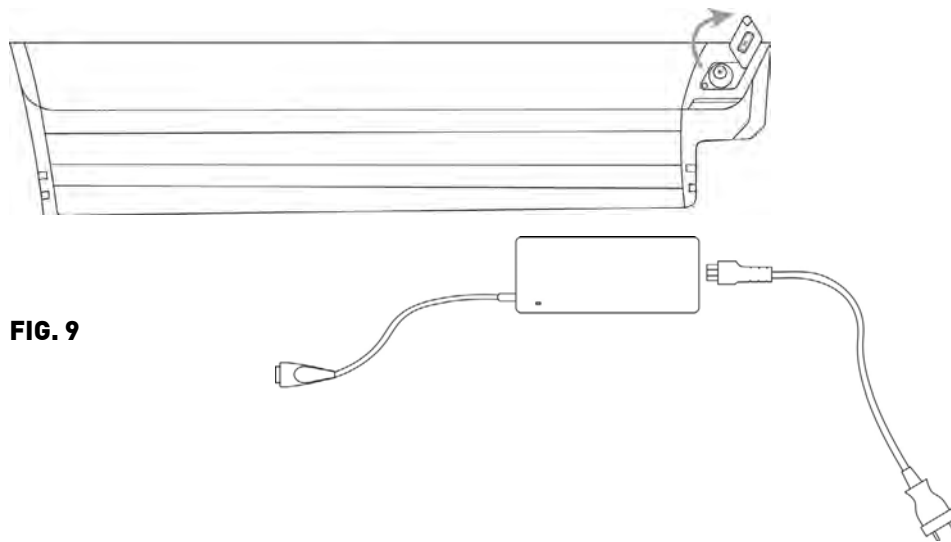

FIG. 9



ATTENTION

BATTERY CHARGER

Always connect the plug to the battery first and then the battery charger to the power outlet.



ATTENTION

BATTERY CHARGE

The battery must not be completely discharged to preserve its life and not run the risk of damaging it. In any case, the same must be recharged at least every 3 months even in case of non-use of the bicycle.



DANGER

PRECAUTIONS WHEN CHARGING

- **Always connect the plug to the battery and then the power plug to the mains;**
- **When charging is complete, always disconnect the plug from the mains first and then the plug from the battery;**
- **Always recharge the battery completely;**
- **Always use the original supplied power supply;**
- **Do not leave the battery charging longer than necessary;**
- **Always recharge in a ventilated environment;**
- **Do not recharge the battery in too hot environments;**
- **Do not recharge the battery in the vicinity of flammable liquids;**
- **Do not cover the battery in any way while charging;**
- **If the battery smells bad, immediately unplug from the mains to ventilate the room. Do not touch the battery.**



6.2 Preliminary functional checks

Before each use, the driver must ensure the safety status of the pedal-assisted bicycle. Therefore, perform the following inspections before riding the pedal-assisted bicycle.

6.2.1 Control devices

Check the efficiency and state of charge of the battery. Use in a very cold environment quickly degrades battery efficiency. Check the tension and lubrication of the chain.

6.2.2 Wheels

Check the tire inflation pressure. Check the state of wear of the tread: there must be no cuts, cracks, foreign bodies, abnormal bulges, visible canvases and other damage.



ATTENTION

Do not inflate tires beyond the permissible value reported by the manufacturer on the side surface of the tires.

6.2.3 Braking

Perform a visual inspection of the braking system verifying that there are no damaged cables or lubricants in the braking surfaces of the brake discs. Check the operation of the brakes with a low-speed braking test on flat, obstacle-free terrain, first with the rear brake and then with the front one.



ATTENTION

NEGATIVE VERIFICATION

In the event that, during the preliminary checks, defects of any kind should be found and even a single verification is negative, DO NOT RIDE THE PEDAL-ASSISTED BICYCLE. Immediately activate all measures to carry out a proper repair and, if necessary, contact the authorized dealer or an authorized workshop.



6.2.4 Frame, handlebar and saddle position

Check that the saddle and handlebars are properly attached to the frame and positioned in the most comfortable configuration for the rider, for complete control of the bicycle. Otherwise, before departure, act on the systems for adjusting the position of the saddle and handlebars. For more information on the regulation refer to section 2.6.

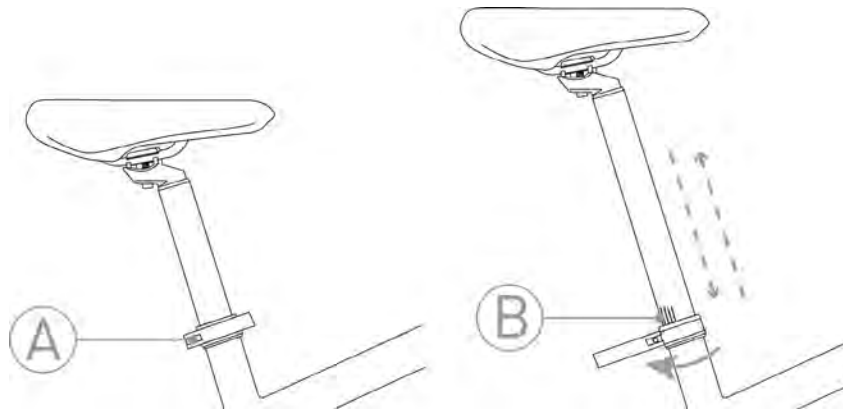

FIG. 1



IMPORTANT NOTICE:
Check that the minimum insertion mark (B) is not visible.



FRAME POSITION

It is strictly forbidden to use the bicycle without having correctly fixed all the parts and used the adjustments to assume a comfortable and safe riding position.

6.2.5 Brake adjustment

Adjust the brake lever to ensure a firm grip of the handlebars even during braking.

To apply maximum braking power to the lever it is possible to make the following adjustments:

- Rotate the brake lever using the clamping screw (Ref. T - Figure 15) until you reach a comfortable position of the hand.

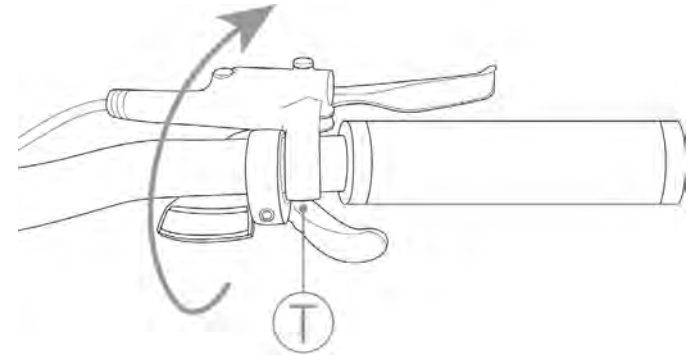

FIG. 15



ATTENTION

An excessive stroke of the brake lever leads to the contact of the same with the knob limiting the braking action and causing the possible crushing of the fingers.

6.2.6 Suspension adjustment

At this point adjust the suspension to make the use of the pedal-assisted bicycle more comfortable.

Depending on the route and the load on the vehicle, it is possible, by means of a special manettino placed on the right side of the fork (Ref. Q - Figure 14), to vary the stiffness of the same.

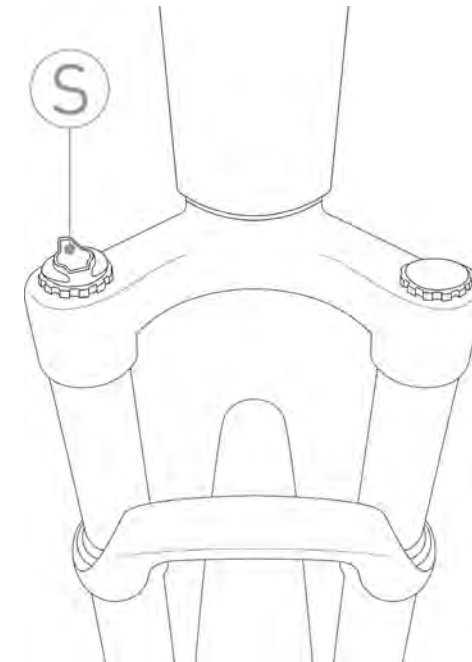

FIG. 14



DANGER

ADJUSTMENTS

It is strictly forbidden to regulate the devices of the bicycle if you are not an experienced and educated person to do so. Incorrect regulation can lead to serious injuries. Therefore, if you are not able to regulate these functions, contact specialized personnel.

The manufacturer is not liable for accidents resulting from incorrect adjustment of the pedal-assisted bicycle devices.



6.2.7 Headlight operation

Before using the pedal-assisted bicycle, check that the front and rear lights are working properly. For more information on switching them on and off, please refer to section 3.5.7.

7. USE OF THE BICYCLE

The pedal-assisted bicycle has been designed and built for use in open places, with asphalt bottom or similar, for amateur use.

- It can only be used by experienced adults and children;
- The use of the pedal-assisted bicycle is not recommended for pregnant women;
- Do not take alcohol or drugs before riding the pedal-assisted bicycle;
- Don't ask your pedal-assisted bike for performance that's superior to what it was designed for. Use the bike only in the manner and intended uses described in this manual;
- Never ride the pedal-assisted bicycle with disassembled parts;
- The pedal-assisted bicycle cannot be used on very wet, icy or slippery surfaces;
- Avoid very uneven surfaces and obstacles;
- Ride with both hands on the handlebars;
- Replace worn and/or damaged parts. Possibly, if necessary, have it checked by authorized personnel;

Before leaving, carry out all the checks reported in the previous chapter and always keep focused while driving, for your own safety and that of others



DANGER

RISK OF ACCIDENTS

- **Verify that all commands are fully functional;**
- **Always respect the highway code;**
- **Use the appropriate protective equipment (helmet, etc.)**



7.1 Use of the bicycle

Before using the pedal-assisted bicycle in places open to traffic, it is advisable to familiarize yourself with the behavior of the vehicle. The first uses must be made in private environments away from traffic, other cyclists and obstacles of any kind. The driver must adapt the driving speed of the pedal-assisted bicycle to the conditions of the route and the presence of other vehicles or pedestrians. Especially when facing curves you have to keep a moderate speed (the smaller the radius of the curve, the lower the speed). When the driver stops pedaling or the speed reaches 25 km/h, the electric motor no longer provides assistance and the bicycle proceeds completely managed by the Pedals.

It is essential to gain experience in driving the pedal-assisted bicycle, before proceeding at a high speed. In case you do not want to use the motor, simply remove the battery or set the lower level of assistance.

7.2 Braking

To minimize the stopping distances of the vehicle it is necessary to suddenly stop pedaling and, subsequently, apply braking force gradually so as not to destabilize the middle.

Encourage the use of the rear brake under braking to stabilize the bicycle.



ATTENTION

DRIVING CONDUCT

Excessive braking force can trigger harmful phenomena such as locking the wheel or overturning the vehicle. It is very dangerous to brake when cornering: you may lose control of the bike.

7.3 Bicycle parking

The bicycle is equipped with a stand for lateral support, therefore, before leaving the bicycle check that the stand is completely extended and resting on a stable ground.

The bicycle must be parked in the prepared parking areas and, in any case, without obstructing the passage paths, emergency exits, electrical panels and workstations antifire.



8. MAINTENANCE

8.1 General



DANGER

RISK OF ACCIDENTS

During all maintenance work, follow the appropriate safety measures. All maintenance operations must be carried out with the battery disconnected from the pedal-assisted bicycle and the battery charger; the bicycle must be supported in a stable manner using special support elements.

To maintain the full functionality of your pedal-assisted bicycle for a long time, it is necessary to carry out maintenance as described, with correctness and professional skills.

After each routine maintenance, a check on the perfect functioning of all the controls is mandatory.

8.2 Daily maintenance and checks

8.2.1 Tag and pictograms check

Check the legibility and presence of the CE plate, and the warning stickers applied to the body of the bicycle.

8.2.2 Wheel control

Through the special inflation valve on the rims, check the inflation pressure of the tires using a compressor and a gun with pressure gauge, or a pump.

Check the status of the tread, the rim and the attachment of the rims to the hubs. In case of tyre replacement, please contact your authorized dealer or a qualified tyre dealer.

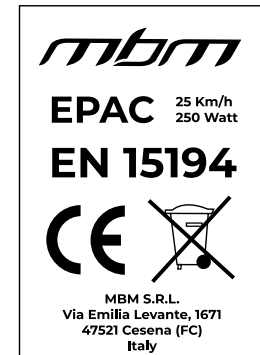

ATTENTION

Do not inflate the tyres beyond the permissible value reported by the player in the lateral surface of the same.



8.2.3 Brake operation control

The brakes must be adjusted in such a way as to ensure effective braking and, at the same time, the control levers must have an adequate stroke to be able to modulate braking: in other words the brakes must not be too slow or too pulled.



ATTENTION

Brake adjustment should only be carried out by authorized personnel.

8.3 Weekly maintenance and checks

8.3.1 Washing and cleaning

The cleaning of the pedal-assisted bicycle is not only a matter of decorum, but also allows you to immediately detect a possible defect in the same.

In order not to damage or compromise the operation of the various components, especially the electrical parts, cleaning must be carried out taking some precautions. It is absolutely forbidden to direct jets of pressurized water towards the electrical parts, the motor and the battery, for which sponge washing is recommended.

Before starting the pedal-assisted bicycle, dry completely with low-pressure compressed air and check that there is no residual moisture left on the electrical components

8.3.2 Lubrication and chain tension control

It is important to periodically clean and lubricate the chain to avoid corrosion due to weathering.

- Wipe the entire length of the meshes with a rag.
- Spray on all meshes a special grease in spray for transmission chains.

Check the correct tension of the chain by placing the gear-box in the two different extreme positions allowed by the sprocket pack.



CORRECT CHAIN LUBRICATION

Be extremely careful not to let go the lubricant on the brakes or tires of the bicycle. This can lead to the occurrence of serious injuries!

8.3.3 Frame and bolt control

The load-bearing frame of the pedal-assisted bicycle and the welds must be free of visible defects such as: cracks, deformations, incisions, corrosions, etc.

Make sure all the bolts of the pedal-assisted bicycle are tightly tightened.



8.4 Monthly maintenance and checks

8.4.1 Control of electrical circuits and components

Check the condition and fixing of the battery cables : the sheaths of the electrical cables must be in good condition and the terminals must be tight, not corroded and if necessary covered with protective grease and specific insulation. Check that all light bulbs and lights have been switched on correctly.

8.4.2 Control and adjustment of the rear derailleur

Adjustment of the lower and upper limit switches of the gearbox: Turn the two screws (Ref. U,T- Figure 16) so that the chain does not come out. The chain shift device must be in line with both the larger and smaller gears (Ref. Figure 17).

Lower limit adjustment

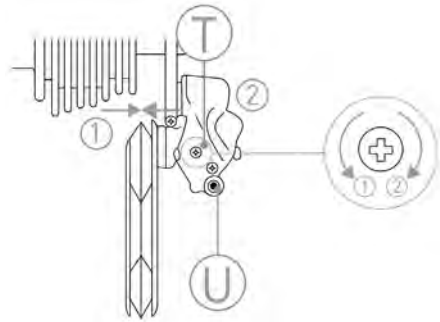

FIG. 16

Upper limit adjustment

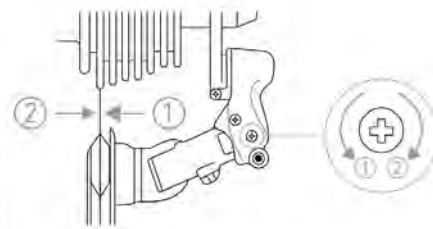

FIG. 17

Adjust the tension of the cable by acting on the appropriate control to ensure the immediate response of the rear derailleur to the control of the manettino placed on the handlebar. (Ref. Figure 18).

To prevent damage to the gearbox, it is recommended not to exert too much pressure on the pedals while changing gear. So avoid changing when making an effort or driving on a slope.

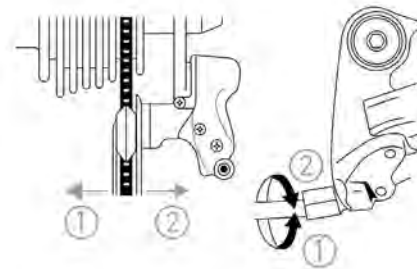

FIG. 18



9. TECHNICAL ASSISTANCE AND SPARE PARTS

If you need technical assistance, please contact your authorized dealer.
In case of assembly of non-original parts, the warranty loses its validity!



ATTENTION

ORIGINAL SPARE PARTS

The manufacturer is exempt from any liability for damages of any kind, generated by the use of non-original spare parts.

10. WAREHOUSE

In the event that the pedal-assisted bicycle should be stored and stored for long periods of inactivity, the following operations must be carried out:

- Repair it in a dry and airy place;
- Perform a general cleaning of the pedal-assisted bicycle;
- Turn off the battery, remove it from the seat and store it in a special storage site (fully charged and recharge it regularly);
- Leave the bike on a special support;
- Protect exposed electrical contacts with antioxidant products;
- Grease all surfaces not protected by paints or anti-corrosion treatments.



11. DISPOSAL OF COMPONENTS AND MATERIALS



ATTENTION

DISPOSAL OF MATERIALS

The disposal of packaging, waste and vacuumed dust, replaced parts and/or the pedal-assisted bicycle as a whole at the end of its intended life must be carried out in environmental respect, avoiding polluting soil, water and air and respecting in any case the national and local legislation in force on the subject.

Indications for waste treatment:

- Ferrous materials, aluminum, copper: these are recyclable materials to be given to a special authorized collection center.
- Plastic materials, fiberglass, gaskets, tires: these are materials to be sent to landfills or recycling centers.
- Batteries must be taken to authorized disposal centers.

Divide the materials according to their nature, commissioning specialized companies authorized to dispose of, in compliance with the provisions of the law.

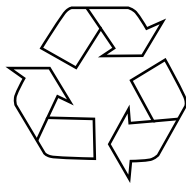

12. WARRANTY RULES

MBM S.r.l. Unipersonale guarantees that its bicycles are free from any manufacturing or workmanship defects. This warranty covers the repair or replacement of any part recognized to be defective, subject to the following conditions:

TERMS AND CONDITIONS

- Warranty period: the pedal-assisted bicycle is guaranteed for 24 months on mechanical and electrical parts, except for batteries and all components subject to wear. The batteries are covered by a conditional warranty for 24 months and limited to proper use of the same:

- first 6 months 100% coverage;
- from the 7th to the 12th month 50% coverage;
- from the 13th to the 24th month coverage of 25%;

If the battery has been left to discharge below the allowed, the manufacturer is not responsible for any damage .

- In order to make this warranty effective, you must fill out the online form which is accessed via QR CODE or connect directly to the site warranty.mbmbike.it by and no later than 15 days from the date of purchase of the bicycle. They will be needed the serial number and the photograph of the proof of purchase of the authorized retailer. The serial number is printed on the label on the battery slide and on the battery itself. (Fig. 19)

- Claims must be made through an official retailer by presenting the original tax document (receipt or invoice) and printing of the confirmation of activation of the warranty that you will receive gradually e-mail after filling out the online form;
- The warranty provides for the free replacement of any defective or prematurely worn part provided that all the requirements have been complied with and the improper use of the bicycle. The manufacturer's obligations are limited to the replacement of defective parts;
- Finally, our Technical Department will decide whether or not the defective part or bicycle falls within the conditions of this warranty;
- This warranty does not cover in any way the replacement of worn parts from normal use of the bicycle;
- This warranty does not apply in any case to failures or damage caused by improper use of the bicycle, use of the bicycle for sports competitions, the application of non-original accessories, or from improper maintenance

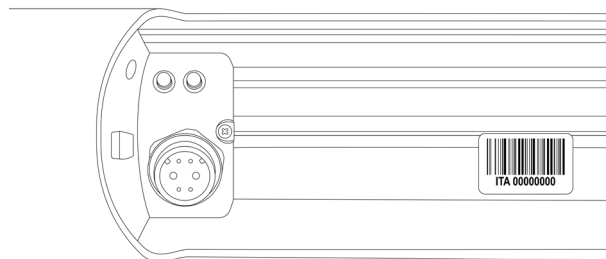

FIG. 19



**ACTIVE HERE
WARRANTY**



EXCLUSIONS

Normal wear and tear on parts subject to it, such as tires, chains, brakes, cables and gear wheels in situations where there are no material defects.

- Bicycles assisted by an unauthorized MBM distributor;
- Changes from the original packaging;
- Use of the bike for abnormal activities, such as competition and/or commercial activities, or for purposes other than those for which the bike was designed;
- Damage caused by non-compliance with the user manual;
- They damage paints and decals as a result of exposing the bike or using it in harsh conditions and climates;
- Labor costs for the replacement of parts;
- Transport costs .

Except as provided in this warranty and remaining subject to all other warranties, MBM and its employees and agents shall not be liable for loss or damage of any kind (including incidental and consequential losses or damages caused by negligence or deficiency) arising out of or relating to any MBM bicycle.

The M.B.M. S.r.l. Unipersonale does not assume responsibility for damage to things and people, due to the improper use of the vehicle.

13. CONFORMITY CE

Hybrid-powered bicycles with a maximum support speed of 25km/h meet the requirements:

1. 2006/42/EC Machinery Directive
2. 2014/30/EU Electromagnetic Compatibility Directive
3. 2011/65/EU Rohs Directive

These bicycles also comply with the following non-harmonized standards :

- Electric bicycles: EN 15194

Disclaimer

It is strongly recommended not to remove or replace any original equipment or to modify the bicycle in any way that may change its design and / or operation. Such modifications could seriously damage the handling, stability and other aspects of the bike, making it unsafe. The removal or modification of parts, or the use of non-original equipment as spare parts, may make the bike no longer comply with applicable rules and laws. To ensure safety, quality and reliability, use only original parts or MBM authorized spare parts for repair and replacement.





M.B.M. S.r.l. Unipersonale

Via Emilia Levante, 1671/73/75 | 47521 Cesena (FC)

Tel.: + 39 0547 -300364

Fax: +39 0547-304326

Email: info@mbmbike.it



W W W . M B M B I K E . I T