

E-METRÒ

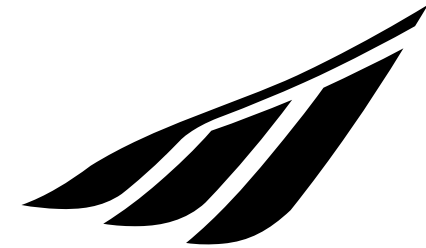

metrò®

USER MANUAL

E-METRÒ

INDEX

| | |
|---|-----------|
| 1. FOREWORD | 3 |
| 1.1 General | 3 |
| 1.2 Assistance | 3 |
| 1.3 Graphic form of safety warnings | 3 |
| 2. SAFETY WARNINGS | 4 |
| 2.1 General safety rules | 4 |
| 2.2 Responsibility | 4 |
| 2.3 Warnings for users | 5 |
| 2.4 Maintenance warnings | 5 |
| 2.5 Other provisions | 6 |
| 2.6 Unpacking and setup | 6 |
| 2.6.1 Saddle adjustment | 6 |
| 2.6.2 Pedal assembly | 7 |
| 3. GENERAL DESCRIPTION | 8 |
| 3.1 General description | 8 |
| 3.2 Technical sheet | 9 |
| 3.3 Brake levers | 10 |
| 3.4 Speed change | 10 |
| 3.5 Assistance system management | 11 |
| 3.5.1 Commands | 11 |
| 3.5.2 Assistance levels | 11 |
| 3.6 Activation of assistance | 11 |
| 3.7 Walk assistance mode | 13 |
| 3.8 Battery | 13 |
| 3.8.1 Battery installation / removal | 13 |
| 3.8.2 State of charge | 13 |
| 3.8.3 Battery charging | 14 |
| 3.8.4 Troubleshooting | 14 |
| 3.9 Front and rear light | 15 |
| 4. TERMS OF USE AND ENVIRONMENT FORESEEN | 16 |
| 4.1 Intended use | 16 |
| 4.2 Environment of use | 16 |
| 4.3 Improper uses and contraindications | 17 |
| 5. LIFTING AND TRANSPORT | 18 |
| 5.1 Lifting | 18 |

| | |
|---|-----------|
| 5.2 Transport | 18 |
| 6. COMMISSIONING | 19 |
| 6.1 Charging the battery | 20 |
| 6.2 Preliminary functional checks | 20 |
| 6.2.1 Control devices | 20 |
| 6.2.2 Wheels | 20 |
| 6.2.3 Braking system | 20 |
| 6.2.4 Frame, handlebar and seat position | 21 |
| 6.2.5 Brake adjustment | 22 |
| 6.2.7 Lights operation | 23 |
| 7. USE OF THE BICYCLE | 24 |
| 7.1 Riding the bicycle | 25 |
| 7.2 Braking | 25 |
| 7.3 Parking the bicyc | 25 |
| 8. MAINTENANCE | 26 |
| 8.1 General | 26 |
| 8.2 Daily maintenance and checks | 26 |
| 8.2.1 Checking the labels and pictograms | 26 |
| 8.2.2 Checking the wheels | 26 |
| 8.2.3 Check brake operation | 26 |
| 8.3 Maintenance and weekly checks | 27 |
| 8.3.1 Washing and cleaning | 27 |
| 8.3.2 Lubrication and chain tension control | 27 |
| 8.3.3 Checking the frame and bolts | 27 |
| 8.4 Maintenance and monthly checks | 28 |
| 8.4.1 Checking the circuits and electrical compo- | 28 |
| 9. TECHNICAL ASSISTANCE AND SPARE PARTS | 29 |
| 10. WAREHOUSE DEPOSIT | 29 |
| 11. DISPOSAL OF COMPONENTS AND MATERIALS | 30 |
| 12. WARRANTY RULES | 31 |
| 13. COMPLIANCE | 32 |



1. FOREWORD

1.1 GENERAL

This manual is an integral and essential part of the E-METRO pedal assisted bicycle.

Before starting it is essential that users read, understand and scrupulously follow the following instructions.

The manufacturer is not liable for damage caused to people and / or things or to pedal assisted bicycles, if they are used incorrectly with respect to the prescriptions indicated. With a view to continuous technological development, the manufacturer reserves the right to modify the components, including the frame without notice, without this manual being automatically updated.

1.2 ASSISTANCE

For any inconvenience or request for clarification, contact the authorized dealer, who has competent and specialized personnel, as well as specific equipment and original spare parts.

1.3 GRAPHIC FORM OF SAFETY WARNINGS

To identify the safety messages in this manual, the following graphic warning symbols will be used. They have the function of attracting the attention of the reader / user for the purposes of a correct and safe use of the pedal assisted bicycle.



ATTENTION

It highlights behavioral rules to keep in order to avoid damage to the pedal assisted bicycle and / or the onset of dangerous situations.



DANGER

It highlights the presence of dangers that cause residual risks to which the user must pay attention in order to avoid injury or material damage.

2. SAFETY WARNINGS



ATTENTION

USE OF THE ASSISTED BICYCLE

Each user must first have read the instruction manual, in particular the chapter on safety information.



ATTENTION

RISKS RELATED TO THE USE OF THE ASSISTED BICYCLE

- **Despite the application of safety devices, for safe use of the pedal assisted bicycle, you must take note of all the provisions relating to the prevention of accidents contained in this manual.**
- **Always remain focused while driving and DO NOT underestimate the residual risks associated with the use of pedal assisted bicycles.**

2.1 GENERAL SAFETY RULES

Even if you are already familiar with the use of pedal assisted bicycles, you must follow the instructions given here, in addition to the general precautions to be observed while driving a motor vehicle. In particular:

- Acquire full knowledge of the pedal assisted bicycle.
- Read the manual carefully to learn about the operation, the safety devices and all the precautions necessary for the safe use of the vehicle. All this to allow safe use.
- Carefully keep the pedal assisted bicycle in perfect working order.

For any inconvenience or request for clarification, please contact the authorized dealer without hesitation, who has competent and specialized personnel, specific equipment and original spare parts.

2.2 RESPONSABILITY

Failure to comply with the operating instructions and safety prescriptions contained in this manual exempts the manufacturer from any liability.

If the maintenance of the pedal assisted bicycle is carried out in a way that does not comply with the instructions provided, with non-original spare parts or in any case in such a way as to compromise its integrity or modify its characteristics, the manufacturer will be relieved of any responsibility relating to the safety of persons. and malfunction of the pedal assisted bicycle.





ATTENTION

UNAUTHORIZED MODIFICATIONS

If you hear unusual noises, or feel something strange, stop the pedal-assisted bicycle immediately. Then carry out a check and, if necessary, contact the authorized dealer.

For any data not included or not deductible from this manual, it is recommended to consult the authorized reseller directly.

2.3 WARNINGS FOR USERS

1. It is forbidden to carry a passenger.
2. Can only be used by experienced adults and children.
3. Do not take alcohol or drugs before riding the pedal assisted bicycle.
4. These pedals assisted bicycle models are designed and built to be used outdoors, on roads and private and public environments.
5. Do not ask the pedal assisted bicycle to perform better than that for which it was designed.
6. Never ride the pedal assisted bicycle with parts that have been disassembled.
7. Avoid uneven surfaces and obstacles.
8. Drive with both hands on the handlebar.
9. Replace worn and / or damaged parts, check that the protections work correctly before use.

2.4 MAINTENANCE WARNING

1. All maintenance operations must be carried out with the battery disconnected.
2. During each maintenance phase, operators must be equipped with the necessary accident prevention equipment.
3. The tools used for maintenance must be suitable and of good quality.
4. Do not use gasoline or flammable solvents as cleaning agents, but always use non-flammable and non-toxic solvents.
5. Limit the use of compressed air for cleaning as much as possible (max 2 bar) and protect yourself with goggles with side shields.
6. Never resort to the use of open flames as a means of lighting when carrying out inspection or maintenance operations.
7. After any maintenance or adjustment, make sure that no tools or foreign bodies are left between the movement parts of the pedal-assisted bicycle.



ATTENTION

ORIGINAL REPLACEMENTS

**Use only original spare parts supplied by M.B.M. S.r.l.
Any liability of the Manufacturer for damage or loss of functionality caused following the use of non-original accessories and parts is excluded.**



2.5 OTHER PROVISIONS

The first thing to do when starting use is to check the presence and integrity of the protections and the operation of the safety devices. If you find any defects, do not use the pedal assisted bicycle!



DANGER

SHELTERS

It is therefore strictly forbidden to modify or remove the guards, controls, labels and information plates.

2.6 UNPACKING AND SETUP

The pedal assisted bicycle is delivered fully assembled and in working condition.

2.6.1 SADDLE AND ADJUSTMENTS

Adjusting the height of the saddle is an essential prerogative for the correct use of the pedal assisted bicycle. Incorrect adjustment can generate structural breaks in the frame.

Adjust the height of the saddle by activating the quick release mechanism (Ref. A - Figure 1). Check that the mechanism is tightened before testing the seat and using the vehicle. Do not raise the saddle beyond the limit switch signal located in the seat post (Ref. B - Figure 1).

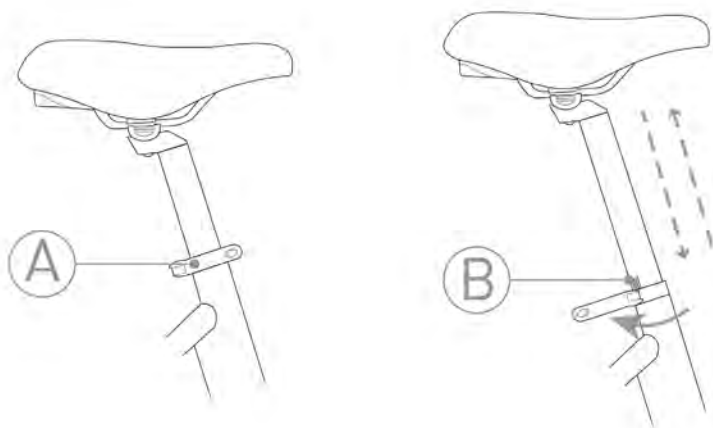

FIG. 1



DANGER

IMPORTANT WARNING:

For your safety, the seat post reference mark (B) should never be outside the tube where the seat post is inserted.



ATTENTION

ASSEMBLY

In the event that you do not have the appropriate instrumentation for adjustment or do not have the skills, contact the authorized reseller.



2.6.2 PEDALS ASSEMBLY

Right Pedal: it is identified by the letter R marked on its pin.
To assemble the pedal, screw it by turning the pin clockwise.
(Figure 4)

Left Pedal: it is identified by the letter L marked on its pin.
To assemble the pedal, screw it by turning the pin counter-clockwise.
(Figure 4)



ATTENTION

ASSEMBLY

In the event that you do not have the appropriate tools for adjustment or do not have the skills, contact the authorized dealer.

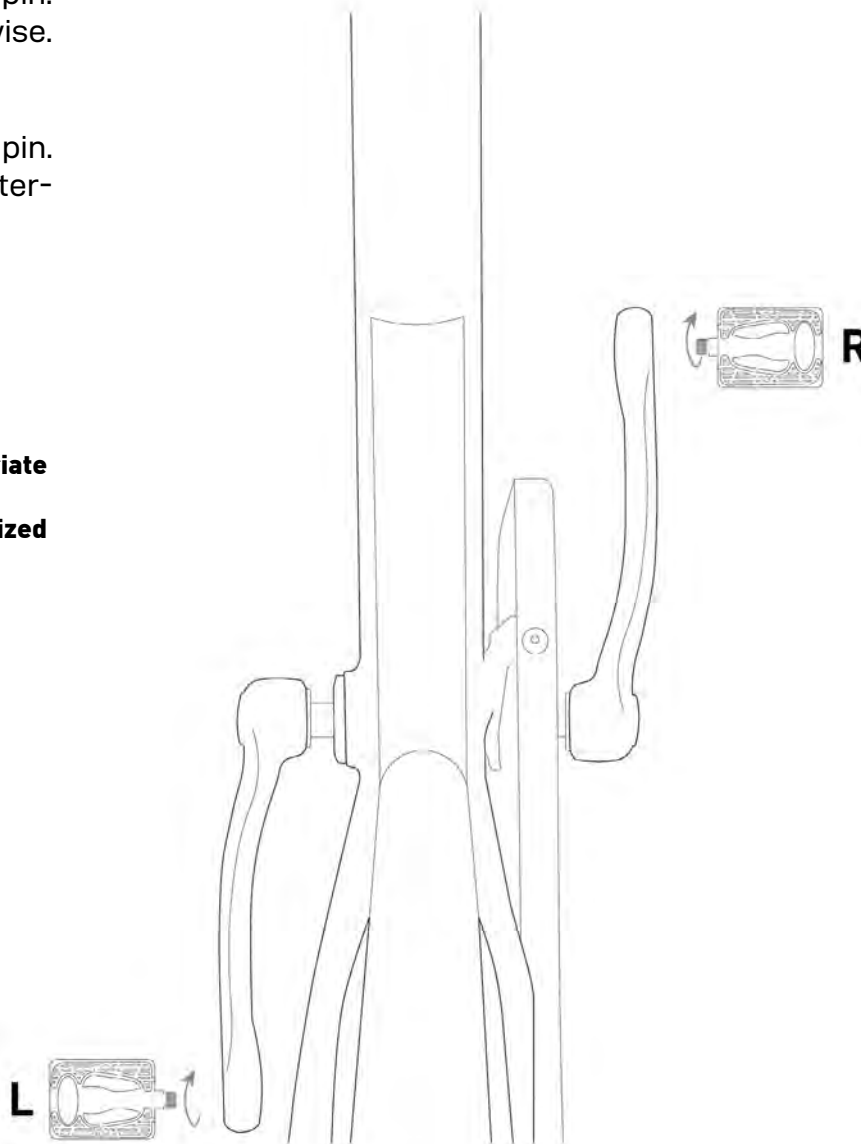

FIG. 4



3. GENERAL DESCRIPTION OF THE BICYCLE

3.1 GENERAL DESCRIPTION

The pedal assisted bicycle is designed and built to be used outdoors, on roads and private or public environments. In particular, the components and the type of pedal assisted bicycle allow you to tackle routes with asphalted surfaces or with similar characteristics without particular roughness.



INCORRECT AND UNINTENDED USE

The bicycle was designed and built for the specified use; a different use and non-compliance with the technical parameters set by the manufacturer may constitute a dangerous condition for users.

The pedal assisted bicycle is equipped with a rechargeable battery and an electric motor, whose intervention takes place only in conjunction with the pedaling and progressively stops as the vehicle speed approaches 25 km / h, and then comes to a complete stop. at that speed.

To manage the assistance system there is a special control located next to the left grip on the handlebar.

On the right side of the handlebar there is a control system for adjusting the gears.



3.2 Scheda tecnica

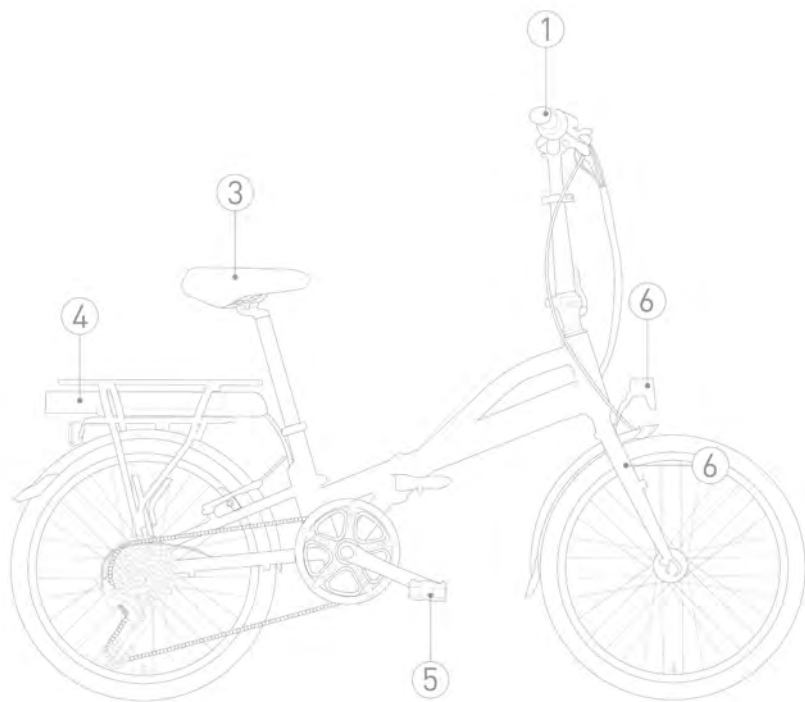

1. HANDLEBAR AND CONTROLS
2. ENGINE
3. SADDLE
4. BATTERY
5. PEDALS
6. FORK
7. LIGHT

| | |
|------------------------|-------------------------|
| CODE | E341 |
| FRAME | ALLUMINIUM |
| FORK | MBM HI-TEN STEEL |
| CRANKSET | 46X170 ALLOY |
| REAR DERAILLEUR | SHIMANO TY300 |
| SHIFTER | 7 SPEEDS |
| BRAKES | V-BRAKE |
| WHEELS | 20X2.00 |
| SADDLE | BASSANO |
| LIGHTS | LIGHTS BATTERY |
| MOTOR | REAR HUB |
| BATTERY | TO THE RACK |
| SPEED | 25 KM/H |
| DISPLAY | LCD |
| POWER LEVELS | 5 LEVELS |
| WEIGHT | 21 KG |



3.3 BRAKE LEVERS

The brake levers (Ref. F - Figure 5) are located on the handlebar of the pedal assisted bicycle, near the knobs (Ref. G-Figure 5). These systems allow the braking system to be activated by controlling the movement of the pads until they come into contact with the wheel rim. The pads, sliding on special guides obtained in the profile of the rim, generate the friction necessary to stop the motion of the bicycle in proportion to the force applied to the lever. The right brake lever activates the rear brake fixed to the frame while the left brake lever activates the front brake fixed to the fork.

3.4 SPEED CHANGE

The pedal assisted bicycle has a 7-speed gearbox, with the sprockets positioned on the rear wheel hub, selectable using the opposing levers, located at the base of the right knob. The indicator (Ref. H - Figure 5) present in the upper part of the handlebar allows you to view the selected ratio.

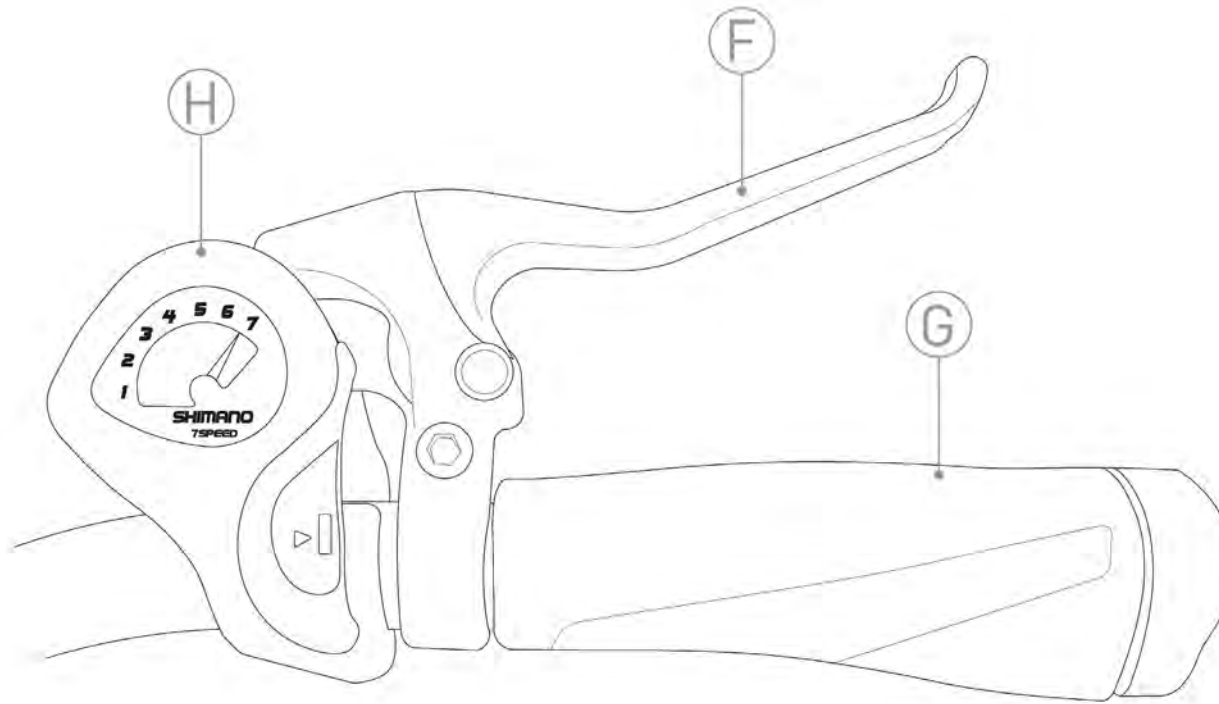

FIG. 5

3.5 ASSISTANCE SYSTEM MANAGEMENT

3.5.1 Commands

To manage the assistance system there is a controller on the left side of the handlebar. This device allows you to vary the level of assistance of the system, to view information regarding the route and the status of the battery.

3.5.2 Assistance levels

To know the exact intensity of assistance, based on the selected value, see below.

LEVEL 1 - 0 ASSISTANCE

LEVEL 2 - ASSISTANCE 25%

Recommended route: plain / hilly - medium-long distances

LEVEL 3 - ASSISTANCE 50%

Recommended route: hilly / medium ascent - medium distances

LEVEL 4 - ASSISTANCE 75%

Recommended route: uphill - medium-short distances

LEVEL 5 - ASSISTANCE 100%

Recommended route: challenging climb - short distance

3.6 ASSISTANCE ACTIVATION

The assistance system is controlled by the controller on the handlebar, near the left grip. In particular, assistance is activated or deactivated using the "M" button (Ref. L - Figure 6). Once the system is activated, the management display itself (Ref. I - Figure 6) is switched on, through which it is possible to see the activity status of the vehicle. The power of the engine depends on the force impressed on the pedals, according to a multiplication factor based on the level of assistance selected. Assistance decreases linearly until reaching 25 km / h. once this speed is exceeded, assistance is automatically deactivated.

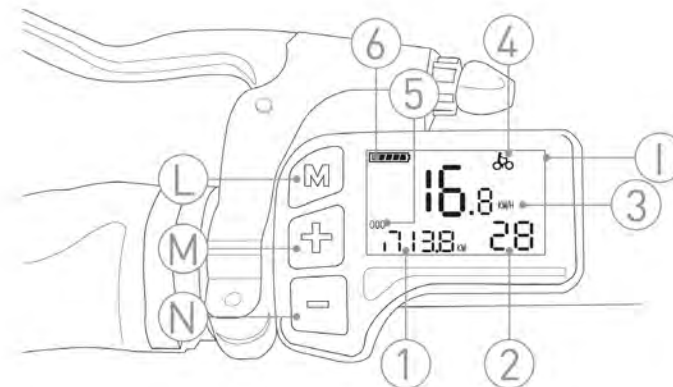

FIG. 6

L - Press and hold to turn on / off.
Press instantly to change the information shown on the display.

M - The button allows you to increase the level of assistance.

N - The button allows you to decrease the level of assistance.

I - The display allows you to view the following information:

- 1- Total distance**
- 2- Time**
- 3- Speed**
- 4- Walk mode**
- 5- PAS level**
- 6- Battery status**



3.7 WALK ASSISTANCE MODE

The pedal assisted bicycle is equipped with the walking assistance function. This function allows you to move the bicycle more easily during manual movement in case you face small climbs.

On flat routes it is useful for starting pedaling, up to a maximum speed of 6 km / h.

To activate the aforementioned mode, turn on the assistance system using the appropriate "M" button (Ref. L - Figure 6). At this point, select an assistance level that is not the minimum and keep the "-" button pressed (Ref. N - Figure 6). Once the "-" button is released, assistance is automatically disabled.

3.8 BATTERY

The assistance system of the pedal assisted bicycle, in order to function, requires the presence of the power supply battery. Specifically, the battery is removable, so it can be removed for maintenance or when you want to store the vehicle.

3.8.1 BATTERY INSTALLATION/REMOVAL

To insert the battery proceed as follows:

1. Insert the battery release key in the slot on the left front part of the luggage rack and turn them counterclockwise (Ref. 1- 2- Figure 7);
2. Insert the battery, making sure to align the guide in the housing with the one in the lower part of the battery. Press the battery until you hear the click of correct insertion (Ref. 2 - Figure 7);
3. Turn the key clockwise (to lock the battery) and remove it (Ref. 3 - Figure 7).

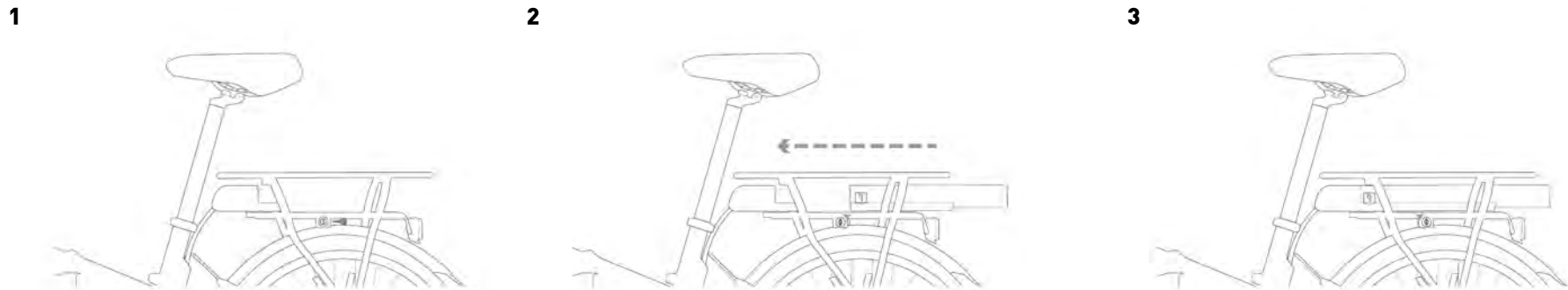

FIG. 7

To remove the battery proceed as follows:

1. Insert the battery release key in the slot in the left front part of the luggage rack (Ref. 1 in Figure 8) and turn it counter-clockwise until the release click occurs;
2. Remove the battery, acting on the appropriate handle at the rear of the same, taking care not to exert excessive force (Ref. 2 in Figure 8);
3. Remove the key (key 3 in figure 8).

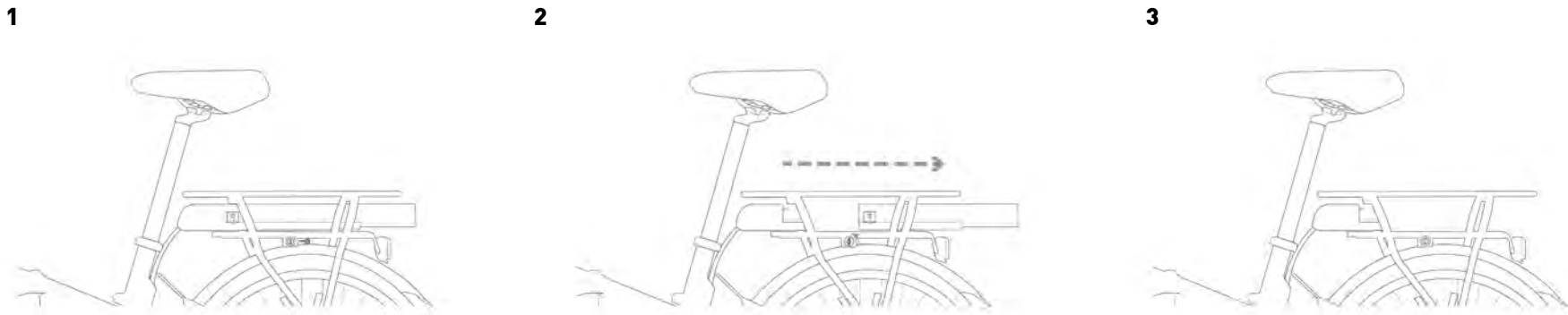

FIG. 8

3.8.2 BATTERY CHARGE STATUS

On the upper side of the battery there is a button to display the state of charge of the same battery. Press the button and wait for the battery charge level LEDs to light up. As the battery is discharged, the notches indicating the state of charge on the display will turn off and then the assistance system will turn off when the system power supply battery is completely discharged. It is also possible to view the state of charge of the battery directly on it, thanks to the 5 LED lights (Ref. O - Figure 9) and the power button (Ref. P- Figure 9), present.

| LED | CHARGE STATUS |
|-----|---------------|
| 1 | 0 - 20 % |
| 2 | 20 - 40 % |
| 3 | 40 - 60 % |
| 4 | 60 - 80 % |
| 5 | 80 - 100 % |

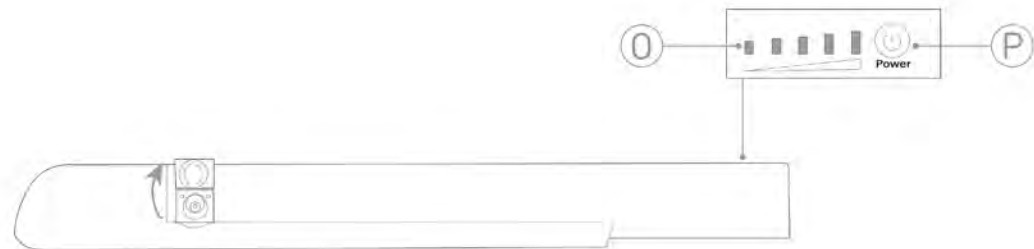

FIG. 9



3.8.3 BATTERY CHARGING

Recharging the battery of the pedal assisted bicycle can be carried out with the battery assembled on the vehicle or removed from it. In particular, proceed as follows:

- 1- Turn off the assistance system of the pedal-assisted bicycle using the appropriate button "M" (Ref. L - Figure 6);
- 2- Remove the battery in case you want to charge the battery separately;
- 3- Lift the rubber cap on the appropriate battery charging socket, located on the left side of the same (Figure 10);
- 4- Connect the supplied battery charger to the socket with the appropriate plug;
- 5- Connect the battery charger to a power socket (230 V / 50 Hz) and let the battery charge for the necessary time.

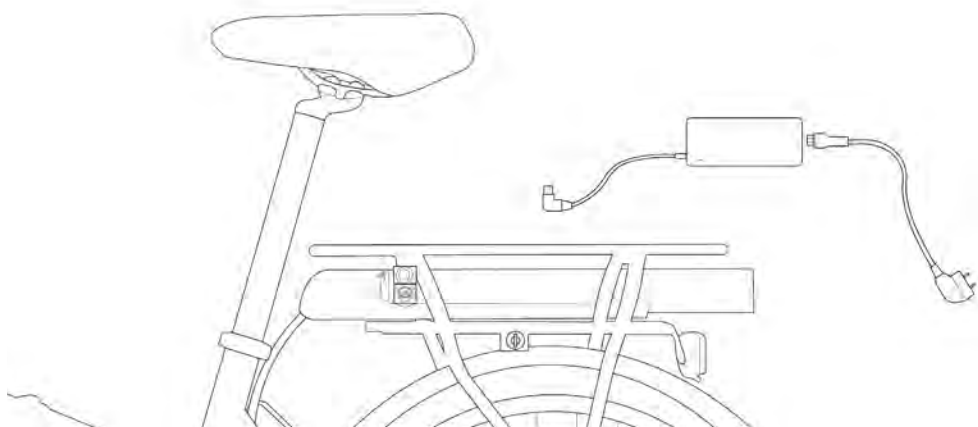

FIG. 10



ATTENTION

CHARGER

Always connect the plug to the battery first and then the battery charger to the power outlet.

3.8.4 TROUBLESHOOTING

| PROBLEM | CAUSE/SOLUTION |
|----------------------------|--|
| The system doesn't turn on | Check if charger is on |
| PROBLEM | CAUSE/SOLUTION |
| Assistance doesn't work | Check if the charging level is sufficient. |



ATTENTION

TROUBLESHOOTING

In the event that the assistance system does not activate even if the battery is charged, contact the authorized dealer.



3.9 FRONT AND REAR LIGHT

To ensure visibility both during the day and at night, two headlights are installed, one front (Figure 11) and one rear (Figure 12). These devices are activated by means of an on / off button (Ref.Q - Figures 11-12).

To replace the batteries, remove the screw (Ref. R - Figures 13-14) and open the device.



FIG. 11



FIG. 12

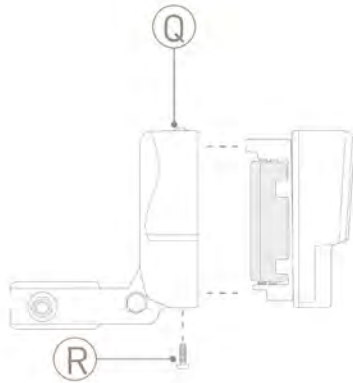

FIG. 13

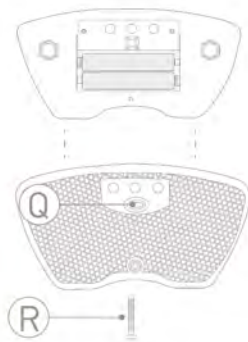

FIG. 14

4. CONDITIONS OF USE AND INTENDED ENVIRONMENTS

4.1 INTENDED USE

The pedal assisted bicycle is designed and built to be used outdoors, on roads and private or public environments. In particular, the components and the type of pedal assisted bicycle allow you to tackle routes with asphalted surfaces or with similar characteristics without particular roughness.

Any modification of the state of construction can compromise the behavior, safety and stability of the pedal assisted bicycle and can lead to an accident.

Other types of use, or the extension of use beyond that envisaged, do not correspond to the destination assigned by the manufacturer, and therefore the same cannot assume any responsibility for any resulting damage.

4.2 ENVIRONMENTS USAGE

The pedal assisted bicycle can be used outdoors, in the absence of adverse weather conditions (heavy rain, hail, snow, strong wind, etc.):

- Maximum allowed temperature: + 40 ° C
- Minimum allowed temperature: +5 ° C
- Maximum permissible humidity: 80%

The environment of use may have an asphalted surface or with not excessively high roughness.

Furthermore, the place of use must be illuminated, by the sun or by artificial lights, in such a way as to ensure the correct view of the path and of the pedal assisted bicycle controls (recommended from 300 to 500 lux). The pedal assisted bicycle is equipped with front white light and rear red light.

FORBIDDEN ENVIRONMENTS

The pedal assisted bicycle must not be used:

- **in areas subject to risk of fire or explosion;**
- **in environments with a corrosive and / or chemically active atmosphere;**
- **in poorly lit environments;**
- **On excessively rough terrain, given its characteristics (frame, wheels, etc.);**
- **In closed spaces, if they do not allow safe use;**
- **In extremely dark environments.**



ATTENTION



4.3 IMPROPER USE AND CONTRAINDICATIONS

The actions described below, which obviously cannot cover the entire range of potential possibilities of “misuse” of the pedal assisted bicycle, are to be considered absolutely prohibited.



ATTENTION

FORBIDDEN OPERATIONS

- **The performance of prohibited operations invalidates the warranty.**
- **The manufacturer declines all responsibility for any damage to property and people resulting from the execution of prohibited operations**



DANGER

PROHIBITED

- **To ride the pedal assisted bicycle for uses other than those for which it was built, that is, the pleasure of a passenger.**
- **Ride the pedal assisted bicycle in areas where there is a danger of explosions.**
- **Ride the pedal assisted bicycle in adverse weather conditions (heavy rain, hail, snow, strong wind, etc.).**
- **Carrying a passenger in addition to the driver.**
- **Riding the pedal assisted bicycle under the influence of alcohol or drugs.**
- **Ride the pedal-assisted bicycle if your weight is greater than the permitted weight.**
- **Charge the battery in an environment that is too hot or not sufficiently ventilated.**
- **Cover the battery while charging.**
- **Smoke or use open flames near the charging area.**
- **Transiting or stopping on sloping (greater than 10%) or excessively bumpy surfaces (with holes, dips, obstacles, etc.).**
- **Perform any maintenance with the battery connected.**
- **Use non-original spare parts.**
- **Insert your limbs or fingers between the moving parts of the bicycle.**
- **Use the pedal assisted bicycle on unpaved or similar terrain.**



5. LIFTING AND TRANSPORT

5.1 LIFTING

The weight of the E - METRÒ model assisted pedal bicycle is such that it can be lifted and transported by one person, also due to its overall dimensions.

The optimal solution for carrying out the movement is to grab a movable part of the handlebar and the rear of the saddle.



DANGER

CRUSHING AND IMPACT

- **During lifting, you must operate with extreme caution to avoid damage to people and property.**
- **This operation must be performed by sturdy people**

The manufacturer is not liable for breakages caused by lifting and / or transporting the pedal assisted bicycle after delivery.

5.2 TRANSPORT

To ensure the safety of transport in vans, it is necessary to prevent the pedal-assisted bicycle from moving. This is achieved by binding it with anchoring bands or cables in good condition.

In this regard, the coupling devices must be installed in such a way as not to damage the frame and other parts of the bicycle.



DANGER

RISK OF INJURY

- **ALWAYS make sure that the frame and handlebar adjustment screws are tightened before each ride. Otherwise, accidents, even serious ones, could result!**



6. COMMISSIONING

6.1 BATTERY CHARGE

Before using the bicycle for the first time, the battery must be charged for at least 24 hours, using the special battery charger, supplied.

The pedal assisted bicycle, model E - METRÒ, is equipped with an electric motor powered by a 37 V lithium-ion battery. The battery pack is housed in the rear part of the bicycle, under the luggage rack.

The average charging time varies from 4 to 6 hours.

The recharging operation can be carried out in a well-ventilated box with the battery installed on the bicycle. To charge the battery proceed as in paragraph 3.8.3.

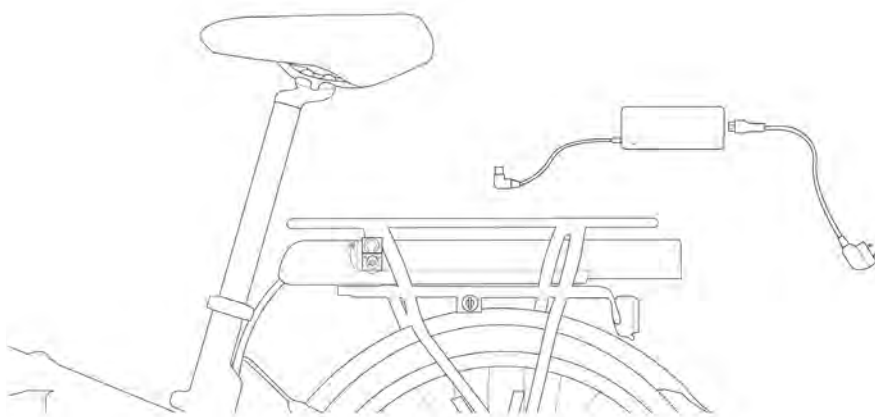

ATTENTION

CHARGER

Always connect the plug to the battery first and then the battery charger to the power outlet.



ATTENTION

LEVEL OF BATTERY CHARGE

The battery should not be fully discharged to preserve its life and not run the risk of damaging it. In any case, it must be recharged at least every 3 months even if the bicycle is not used.



PERICOLO

PRECAUTIONS DURING CHARGING PROCESS

- **Always connect the plug to the battery and then the power plug to the mains.**
- **When charging is complete, always disconnect the plug from the mains first and then the plug from the battery.**
- **Always recharge the battery fully.**
- **Always use the original power supply supplied.**
- **Do not leave the battery charging longer than necessary.**
- **Always recharge in a ventilated area.**
- **Do not recharge the battery in too hot environments.**
- **Do not recharge the battery near flammable liquids.**
- **Do not cover the battery in any way while charging.**
- **If the battery emits a bad smell, immediately disconnect the plug from the power supply and ventilate the room, do not touch the battery.**



6.2 PRELIMINARY FUNCTIONAL CHECKS

Before each use, the driver must check the safety status of the pedal assisted bicycle. Therefore, perform the following inspections before riding the pedal-assisted bicycle.

6.2.1 Control devices

Check the efficiency and state of charge of the battery. Use in a very cold environment quickly degrades the efficiency of the battery. Check chain tension and lubrication.

6.2.2 Wheels

Check the tire inflation pressure. Check the state of wear of the tread: there must be no cuts, cracks, foreign bodies, abnormal bulges, visible plies and other damage.



ATTENTION

Do not inflate the tires beyond the allowable value indicated by the manufacturer on the side surface of the tires.

6.2.3 Braking system

Carry out a visual check of the braking system, verifying that there are no damaged cables or lubricants in the braking surfaces of the brake and rim. Check the operation of the brakes with a low-speed braking test in an obstacle-free area, first with the rear brake and then with the front one. Test the efficiency of the braking system on a flat path and at low speed.



ATTENTION

NEGATIVE TEST

In the event that, during the preliminary checks, defects of any kind are found and even a single check is negative, DO NOT RIDE THE BICYCLE WITH ASSISTED RIDING. Immediately take all measures to carry out an adequate repair and, if necessary, contact the authorized dealer or an authorized workshop.



6.2.4 Frame, handlebar and saddle position

Check that the frame, saddle and handlebars are properly secured and positioned in the most comfortable configuration for the rider for complete control of the bike. Otherwise, before setting off, act on the position and saddle adjustment systems. For further information on regulation, refer to paragraph 2.6.

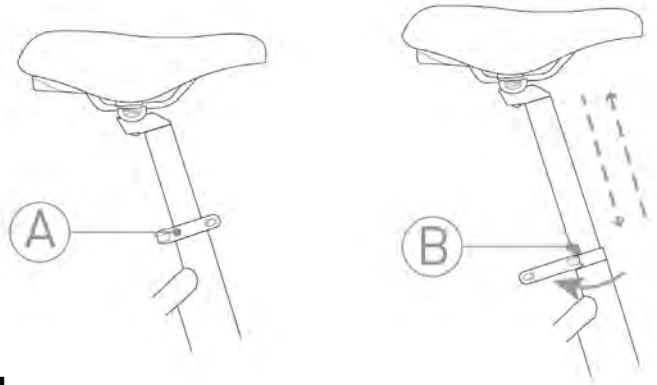

FIG. 1



DANGER

IMPORTANT

Check that the minimum insertion mark (B) is not visible



DANGER

FRAME POSITION

It is strictly forbidden to use the bicycle without having correctly fixed all the parts of the bicycle that were folded and without having assumed a comfortable and safe riding position

6.2.5 Brake adjustment

Adjust the brake lever to ensure a firm grip on the handlebar even when braking.

To apply maximum braking power to the lever, the following adjustments can be made:

- Rotate the brake lever using the tightening screw (Ref. U - Figure 16) until reaching a comfortable hand position.
- Vary the stroke of the brake lever by acting on the adjuster (Ref. T - Figure 16).

Warning: Excessive travel of the brake lever leads to contact of the same with the knob, limiting the braking action and causing possible crushing of the fingers.

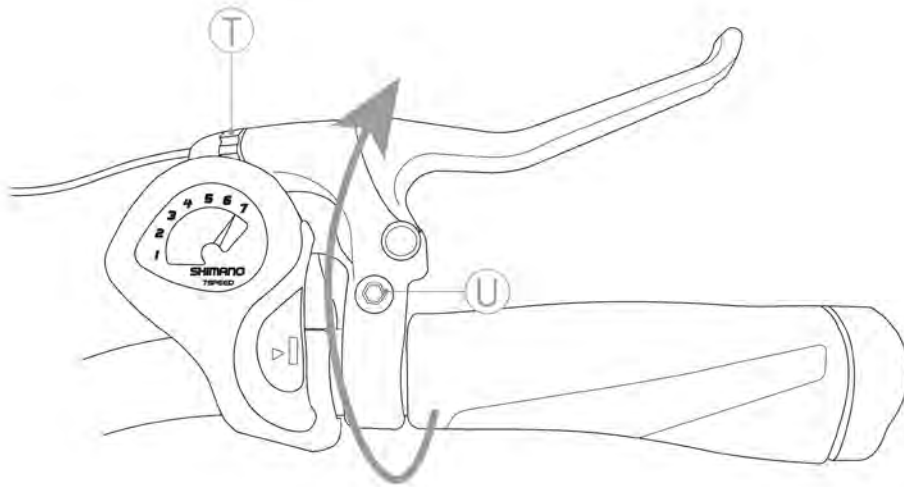

FIG. 16

**REGULATIONS**

It is strictly forbidden to adjust the devices of the bicycle if you are not experienced and trained to do so. Incorrect adjustment can cause serious injuries.

Therefore, if you are unable to adjust these functions, contact specialized personnel.

The manufacturer is not liable for accidents resulting from incorrect adjustment of the

6.2.7 Operation of the lights

Before using the pedal assisted bicycle, check the operation of the front and rear lights by pressing the on / off button (Ref. Q - Figures 11-12). For further information refer to paragraph 3.9.

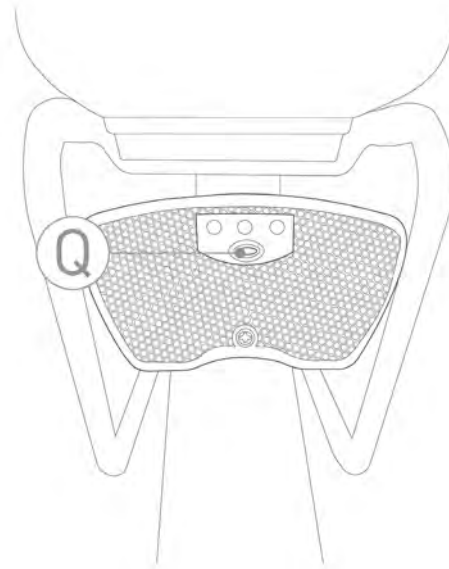
**FIG. 11****FIG. 12**

7. USE OF BICYCLE

The pedal assisted bicycle was designed and built for use in open places, with asphalt surfaces or the like, for amateur use.

- It is forbidden to load a passenger other than the driver.
- Can only be used by experienced adults and children.
- The use of pedal assisted bicycles is not recommended for pregnant women.
- Do not take alcohol or drugs before riding the pedal assisted bicycle.
- Do not ask the pedal assisted bicycle to perform better than that for which it was designed. Use the bicycle only in the manner and for the intended uses described in this manual.
- Never ride the pedal assisted bicycle with parts that have been disassembled.
- The pedal assisted bicycle cannot be used on very wet, icy or slippery surfaces.
- Avoid very uneven surfaces and obstacles.
- Drive with both hands on the handlebar.
- Replace worn and / or damaged parts. Eventually, if necessary, have it checked by authorized personnel.

Before leaving, carry out all the checks described in the previous chapter and always keep concentrated while driving, for your own safety and that of others.



RISK OF INJURY

- **Check that all the controls are perfectly functional.**
- **Always respect the highway code.**
- **Use suitable protective equipment (helmet, etc ..)**



7.1 USE OF BICYCLE

Before using the pedal assisted bicycle in places open to traffic, it is advisable to familiarize yourself with the behavior of the vehicle.

The first uses must be made in private environments away from traffic, other cyclists or obstacles of any kind.

The driver must adapt the travel speed of the pedal assisted bicycle to the conditions of the route and the presence of other vehicles or pedestrians. Especially when tackling the curves, you must keep a moderate speed (the smaller the corner radius, the lower the speed must be). When the driver stops pedaling or the speed reaches 25 km / h, the electric motor no longer provides assistance and the bicycle proceeds completely managed by the pedals.

It is essential to gain experience in riding the pedal assisted bicycle, before proceeding at high speed. If you do not want to use the engine, simply remove the battery or set the lowest level of assistance.

7.2 BRAKING

To minimize the stopping distances of the vehicle, it is necessary to abruptly stop pedaling and subsequently apply braking force gradually in order not to destabilize the vehicle.

Encourage the use of the rear brake when braking to stabilize the bicycle.



ATTENTION

DRIVING CONDUCT

Excessive braking force can trigger harmful phenomena such as wheel locking or vehicle overturning. It is very dangerous to brake when cornering: you could lose control of the bike.

7.3 PARKING THE BICYCLE

The bicycle is not equipped with a side stand for support, therefore, before leaving the bicycle, check that the pedal-assisted bicycle is resting on stable ground and remains in a stable position.

The bicycle must be parked in the designated parking areas and, in any case, without obstructing the passageways, emergency exits, electrical panels and fire-fighting stations.



8. MAINTENANCE

8.1 General features



RISK OF INJURY

During all maintenance work, follow the appropriate safety measures. In this regard, refer to the information on p. 10. All maintenance operations must be carried out with the battery disconnected from the pedal-assisted bicycle and from the battery charger and the bicycle resting in a stable manner, using special support elements.

To maintain the full functionality of your pedal assisted bicycle for a long period, it is necessary to carry out maintenance as prescribed, with correctness and professional skills.

8.2 Daily maintenance and checks

8.2.1 Control of plates and pictograms

Check the legibility and presence of the CE plate, and of the warning stickers affixed to the bodywork of the bicycle.

8.2.2 Wheel control

Using the special inflation valve on the rims, check the inflation pressure of the tires using a compressor and a gun with a pressure gauge, or a pump. Check the condition of the tread, the rim and the attachment of the rims to the hubs. In the event of a tire replacement, contact your authorized dealer or a qualified tire dealer.

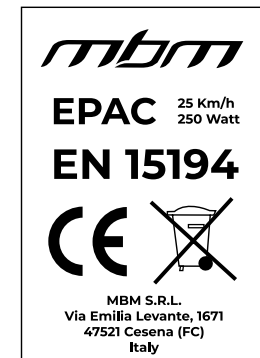

Do not inflate the tires beyond the allowable value indicated by the manufacturer on the side surface of the tires.

ATTENTION

8.2.3 Brake operation check

The brakes must be adjusted in such a way as to ensure effective braking and at the same time the control levers must have adequate travel, in order to modulate the braking: in other words, the brakes must not be too slow or too tight.

Fine adjustment of the brakes

Adjustment of the brakes must only be carried out by authorized personnel.



8.3 Weekly maintenance and checks

8.3.1 Washing and cleaning

Cleaning the pedal assisted bicycle is not only a matter of decorum, but also allows you to immediately detect any defect in it.

In order not to damage or compromise the functioning of the various components, especially the electrical parts, cleaning must be carried out taking certain precautions. It is absolutely forbidden to direct jets of pressurized water towards the electrical parts, the engine and the battery, for which washing with a sponge is recommended.

Before starting the pedal-assisted bicycle, dry completely with low pressure compressed air and check that there is no residual moisture on the electrical components.

8.3.2 Lubrication and chain tension control

It is important to clean and lubricate the chain to prevent corrosion from atmospheric agents.

1. Clean the entire length of the links with a rag.
2. Spray all the links with a special grease in spray for transmission chains.

Verify the correct tension of the chain by placing the cam- bio in the two different extreme positions allowed by the pinion pack



CORRECT LUBRICATION OF THE CHAIN
Be careful not to let the lubricant run on the brakes or tires of the bicycle. This can lead to the occurrence of serious injuries!!

8.3.3 Checking the frame and bolts

The supporting frame of the pedal assisted bicycle and the welds must be free of visible defects such as: cracks, deformations, incisions, corrosion, etc. Make sure that all the bolts on the pedal assist bike are tight.



8.4 Monthly maintenance and checks

8.4.1 Control of circuits and electrical components

Check the condition and fastening of the battery cables: the sheaths of the electric cables must be in good condition and the terminals must be well tightened, not corroded and covered with insulating grease.

Check that all bulbs and warning lights are switched on correctly.

8.4.1 Control and adjustment of the rear derailleur

Adjusting the lower and upper limit switches of the rear derailleur: Turn the two screws (Ref. V-Z - Figure 19) so that the chain does not come out. The chain displacement device must be in line with both the larger gear and the smaller one (Rif. Figure 20)

Lower limit adjustment

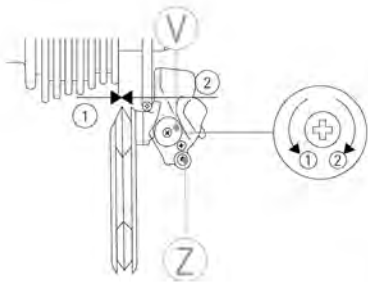

FIG. 19

Upper limit adjustment

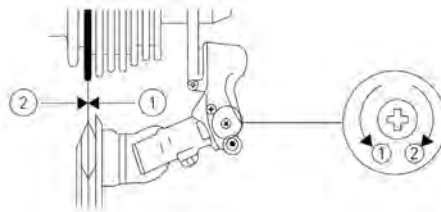

FIG. 20

Adjust the tension of the cable by acting on the appropriate control to ensure the immediate response of the rear derailleur to the control of the handle on the handlebar. (Ref. Figure 21)

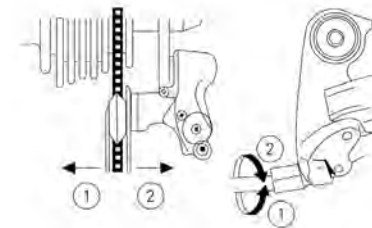

FIG. 21

To prevent damage to the gearbox, it is recommended not to exert too much pressure on the pedals while shifting gears. So avoid shifting when exerting effort or driving on slopes.

9. ASSISTANCE AND SPARE PARTS TECHNIQUE

If you need technical assistance, contact your authorized dealer. If non-original parts are fitted, the guarantee becomes invalid!



ATTENTION

ORIGINAL REPLACEMENTS

The manufacturer disclaims any liability for damage of any nature, generated by the use of non-original spare parts.

10. DEPOSIT AND WAREHOUSE

In the event that the pedal assisted bicycle should be stored and kept for long periods of inactivity, the following operations must be carried out:

- Repair it in a dry and ventilated place.
- Carry out a general cleaning of the pedal-assisted bicycle.
- Remove the battery from its seat and place it in a special storage site (fully charged and recharge regularly).
- Leave the bicycle on a suitable support.
- Protect exposed electrical contacts with antioxidant products.
- Grease all surfaces not protected by paints or anti-corrosion treatments.



11. DISPOSAL OF COMPONENTS AND MATERIALS



ATTENTION

DISPOSAL OF COMPONENTS

The disposal of packaging, waste and vacuumed dust, the replaced parts, the pedal assisted bicycle as a whole at the end of its expected life, must be carried out in respect of the environment; avoiding to pollute the soil, water and air, respecting in any case the national and local legislation in force on the subject.

Indications for waste treatment:

- Ferrous materials, aluminum, copper: these are recyclable materials to be given to a specific authorized collection center.
- Plastic materials, fiberglass, gaskets, tires: these are materials to be sent to landfills or to a special recycling center.
- Batteries must be taken to authorized disposal centers.

Divide the materials according to their nature, appointing specialized companies authorized to dispose of them, in compliance with the provisions of the law.

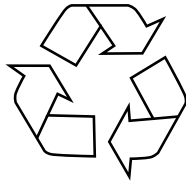

12. WARRANTY RULES

MBM srl guarantees that its bicycles are free from any manufacturing or invoice defect. This warranty covers the repair or replacement of any part which is found to be defective, subject to the following conditions.

TERMS AND CONDITIONS

- Warranty period: the pedal assisted bicycle is guaranteed for 24 months on the mechanical and electrical parts, except for the batteries and all components subject to wear. The batteries are covered by a conditional warranty for 24 months and limited to their correct use:

- first 6 months 100% coverage;
- from the 7th to the 12th month 50% coverage;
- from the 13th to the 24th month 25% coverage;

If the battery has been allowed to discharge below the permitted limit, the manufacturer is not liable for any damage.

- In order to make this warranty effective, you must fill in the online form which can be accessed via the QR CODE or by connecting directly to the warranty.mbmbike.it website no later than 15 days from the date of purchase of the bicycle. You will need the serial number and a photograph of the proof of purchase from the authorized dealer. The serial number is printed on the plate affixed to the straight tube of the bicycle at the bottom bracket.

- Claims must be made through an official dealer by presenting the original fiscal document (receipt or invoice) and printing the confirmation of the activation of the guarantee that you will receive via e-mail after filling out the online form.

- The warranty provides for the free replacement of any defective or prematurely worn part as long as all the requirements have been respected and there is no improper use of the bicycle. The manufacturer's obligations are limited to the replacement of defective parts.

- Ultimately, our Technical Department will decide whether or not the defective part or bicycle falls within the conditions of this warranty.

- This warranty does not cover in any way the replacement of parts worn out by normal use of the bicycle.

- This warranty does not apply in any case to breakdowns or damage caused by improper use of the bicycle, use of the bicycle for sports competitions, by the application of non-original accessories, or by improper maintenance interventions.



**ACTIVATE THE
WARRANTY HERE**



EXCLUSIONS

Normal wear and tear on parts subject to it, such as tires, chains, brakes, cables and sprockets in situations where there are no units or material defects.

- Bicycles serviced by an unauthorized MBM distributor.
- Changes from the original packaging.
- Use of the bike for abnormal activities, such as competition and / or commercial activities, or for purposes other than those for which the bike was designed.
- Damage caused by not following the user manual.
- Damage to paints and decals as a result of having exposed the bike or having used it in harsh conditions and climates.
- Labor costs for the replacement of parts.
- Transportation fee.

Except as provided in this warranty and remaining subject to all other warranties, MBM and its employees and agents will not be liable for loss or damage of any kind (including incidental and consequential losses or damage caused by negligence or failure) originating from or relating to any MBM bicycle.

M.B.M. S.r.l. does not assume responsibility for damage to property and people, due to improper use of the vehicle.

13. COMPLIANCE

Hybrid-drive bicycles with a maximum support speed of 25km / h fulfill the requirements:

- 2006/42 / EC Machinery Directive
- 2014/30 / UE Electromagnetic Compatibility Directive
- 2011/65 / EU Rohs Directive

These bicycles also comply with the following non-harmonized standards:

- Electric bicycles: EN 15194

Disclaimer:

It is strongly recommended that you do not remove or replace any original equipment or modify the bicycle in any way that could change its design and / or function. Such modifications could seriously damage the handling, stability and other aspects of the bicycle, making it unsafe. The removal or modification of parts, or the use of non-original equipment as spare parts, can make the bike no longer compliant with applicable standards and laws. To ensure safety, quality and reliability, use only MBM original parts or authorized spare parts for repair and replacement.





M.B.M. Srl

Via Emilia Levante, 1671/73/75 | 47521 Cesena (FC)

Tel.: + 39 0547 -300364

Fax: +39 0547-304326

Email: info@ciclimbm.it



W W W . M B M B I K E . C O M